

ECOFRIO v2 / ECOFRIO v2 Plus Air cooled chiller / heat pump

YLCA 12 to 27 / YLHA 12 to 27 Plus
A complete range from 12 kW up to 25.8 kW



Features

- Scroll compressor units
- Very compact units
- High efficiency units
- Leaving and return water temperature control
- Hydro pack standard
- Buffer tank supresion function
- Dynamic set point function
- Fan speed control as standard
- Coated condenser fins as standard (blue fin)
- Flow switch and water filter included

Options / Accessories

- Condenser copper fins
- BMS Communication
- Remote control / Remote terminal
- High pressure fans
- External buffer tank
- Tray cable heater (YLHA Plus)
- Condenser protection grill

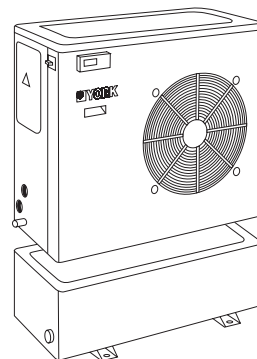

External Buffer tank in accessories

ECOFRIO v2 / ECOFRIO v2 Plus

YLCA 12 to 27 / YLHA 12 to 27 Plus



Technical features

T Three phases supply C Hydro Pack

Model	YLCA G1				YLHA PLUS G1					
	12 TC	15 TC	20 TC	27 TC	12 TC	15 TC	20 TC	27 TC		
Performance	Cooling capacity (1)	kW	12.4	14.5	19.5	25.6	12	13,8	19.4	25.8
	Total Input Power (1)	kW	4.2	5.4	6.9	9,1	4.2	5.5	7	8.9
	EER (1)		2.97	2.52	2.81	2.81	2,88	2,52	2,75	2,9
	ESEER		3.20	2.91	3.24	3.17	3.08	2.91	3.17	3.25
	Heating capacity (1)	kW	-	-	-	-	12,4	16,1	20,9	27,5
	Total Input Power (1)	kW	-	-	-	-	4.2	5.2	6.6	8.6
	COP (1)		-	-	-	-	3.0	3,12	3,17	3,2
	Heating capacity (2)	kW	-	-	-	-	12.6	16.4	20.5	26.8
	COP (2)		-	-	-	-	3,86	4.0	3,79	3,8
	Capacity steps	%	0 / 100							
Sound power level	dB(A)	73	73	74	78	73	73	74	78	
Sound pressure level at 10 m	dB(A)	43	43	44	48	43	43	44	48	
Compressor	Type	Scroll								
	Quantity	1								
Air side heat exchanger	Fans quantity	2								
	Working ambient temp. cool / heat mode	(5) (-18°C) -10°C ~ 46°C		-18°C ~ 46°C		-18°C - 46°C / -15°C ~ 20°C				
Water side heat exchanger	Type	Plate Heat Exchanger								
	Unit water volume	Litres	1.5	2	2.8	3.2	1.5	2	2.8	3.2
	Pump Type	Multi stage								
	Nominal water flow in cooling	l/h	2 065	2 530	3 360	4 405	1 980	2 375	3 335	4 440
	Available pressure (1) (3)	kPa	113	149	129.5	182	116	157.5	124	182
	Working water leaving temp. cooling/heating mode (4)	°C	-5°C to 15°C / 30°C to 50°C							
	Water connections	inch	1"	1 1/4"			1"	1 1/4"		
Dimensions & Weight	Height / Width / Depth	mm	1 270 / 905 / 460	1270/1430/502	1270/1876/502	1 270 / 905 / 460	1270/1430/502	1270/1876/502	1270/1876/502	
	Weight	kg	146	160	220	290	150	164	235	330
Electrical features	Voltage / Phases / Frequency	V/ph/hz	400-3-50+N+E							
	Maximum Unit current	A	11.6	15.8	18.1	23	11.6	12.4	15.5	21

(1) net values at Nominal conditions (2) net values at floor heating conditions (3) with filter (4) below 6°C with glycol (5) -18°C with LAK option
 Nominal conditions: Cooling capacities for 7°C water leaving temperature Δt 5°C and 35°C ambient temperature
 Heating capacities for 45°C water leaving temperature Δt 5°C and 7°C ambient temperature
 Floor heating conditions: Heating capacities for 35°C water leaving temperature Δt 5°C and 7°C ambient temperature

Compatibility table / Codes

YLCA Model	12 TC	15 TC	20 TC	27 TC				
Cooling only units (Pack included)	S668551282	S668551582	S668552082	S668552782				
YLHA Plus Model	12 TC	15 TC	20 TC	27 TC	12 TC	15 TC	20 TC	27 TC
Heat pump units (Pack included)					S668651285	S668651585	S668652085	S668652785

Use this unit code when a factory fitted option is NOT required

Accessories (Supplied loose)

Water tank	30 Liters	S613990300	-	S613990300	
	115 Liters	-	S613991150	-	S613991150
Water tank + heater	30 L + 4.5 kW (3~)		-	S613990305	-
	30 L + 6 kW (3~)		-	S613990306	-
	115 L + 10.5 kW (3~)		-		S613991151
Remote control				S613802011	
Remote terminal				S613802231	
BMS Communication				S613802041	
Anti vibration mounting	S613029001		S613029002	S613029001	S613029002
Compressor heater	S613760322		STANDARD	S613760322	STANDARD
Tray cable heater					S611080788

YLCA Model	12 TC	15 TC	20 TC	27 TC				
Cooling only units (Pack included)	S668000010	S668000012	S668000014	S668000016				
YLHA Plus Model	12 TC	15 TC	20 TC	27 TC	12 TC	15 TC	20 TC	27 TC
Heat pump units (Pack included)					S6686000239	S6686000242	S6686000243	S6686000244

Use this unit code when a factory fitted option is required

Options (Factory fitted)

High pressure fans	S611991083		S611991085	S611991083	S611991085
Condenser protection grill	S613995085	S61399086	S61399087	S613995085	S61399086
LAK -18°C	S613112083			STANDARD	

Dimensions, hydraulic connections and space requirements

YLCA-YLHA PLUS 12/15 TC

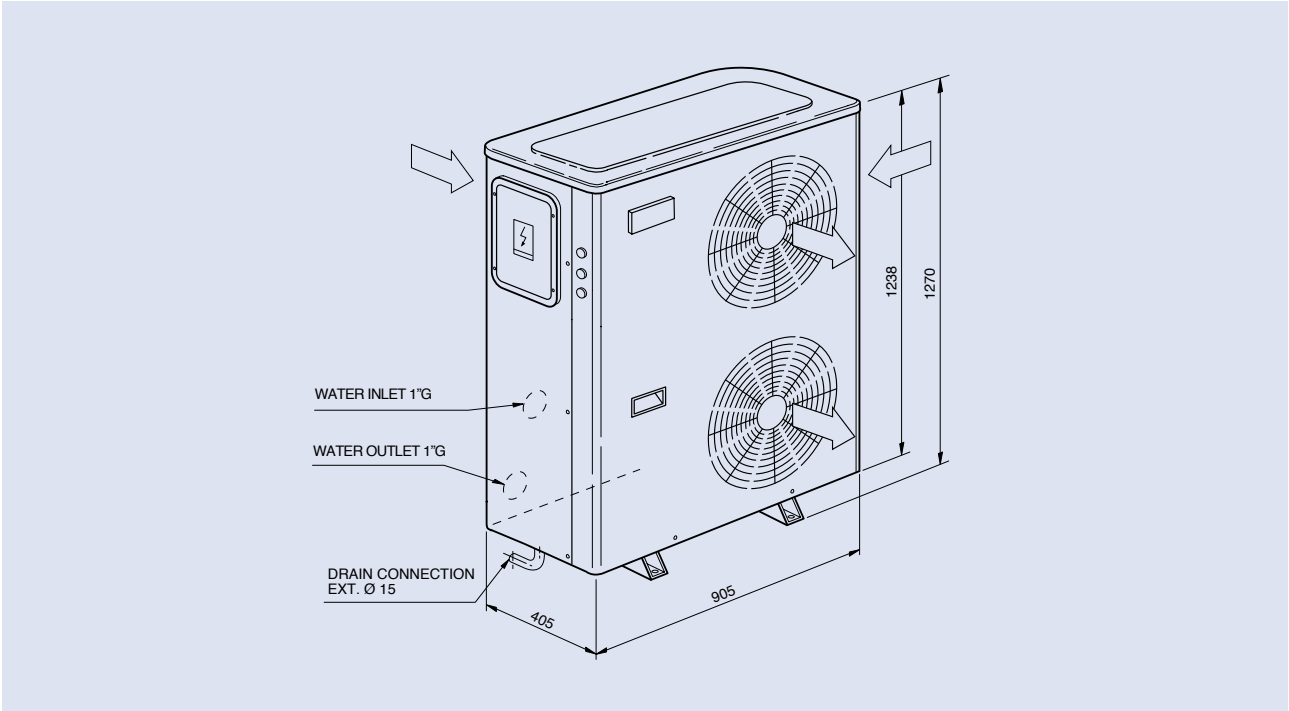

All dimensions in mm. Drawings not a scale.

YLCA-YLHA PLUS 20/27 TC

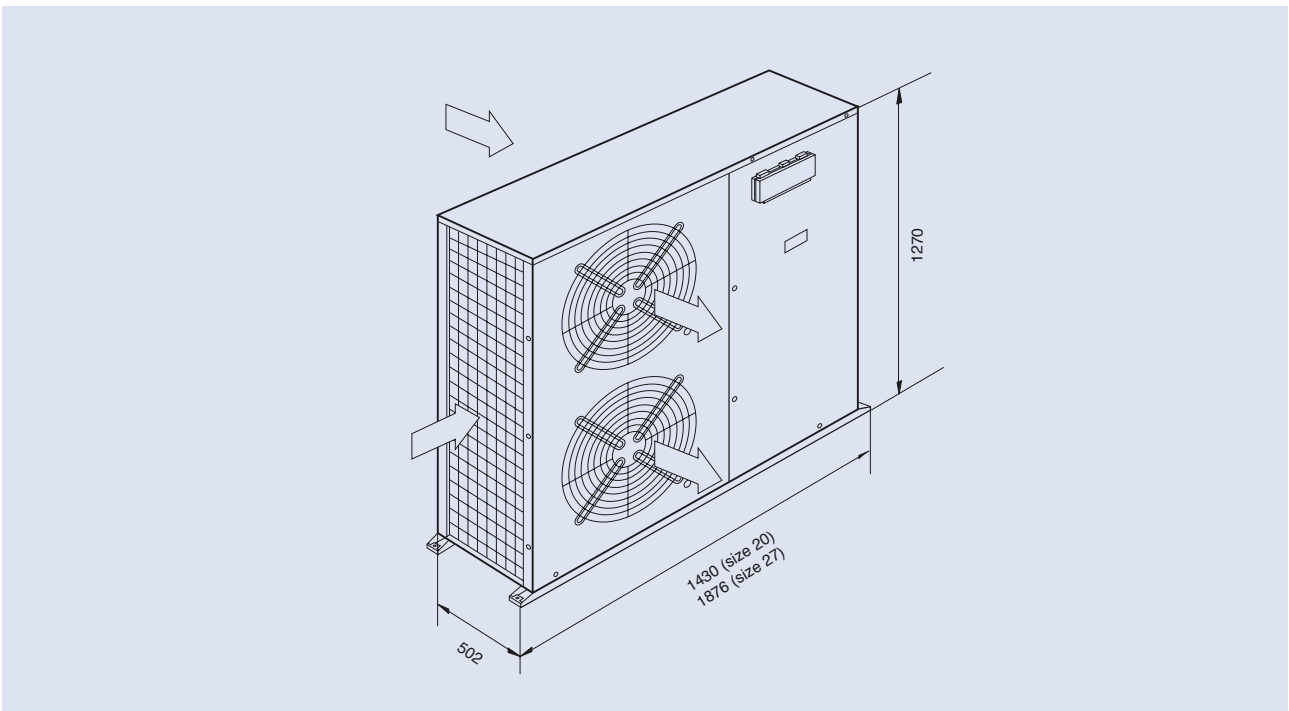

All dimensions in mm. Drawings not a scale.

Dimensions, hydraulic connections and space requirements

Models YLCA-YLHA PLUS 12/15

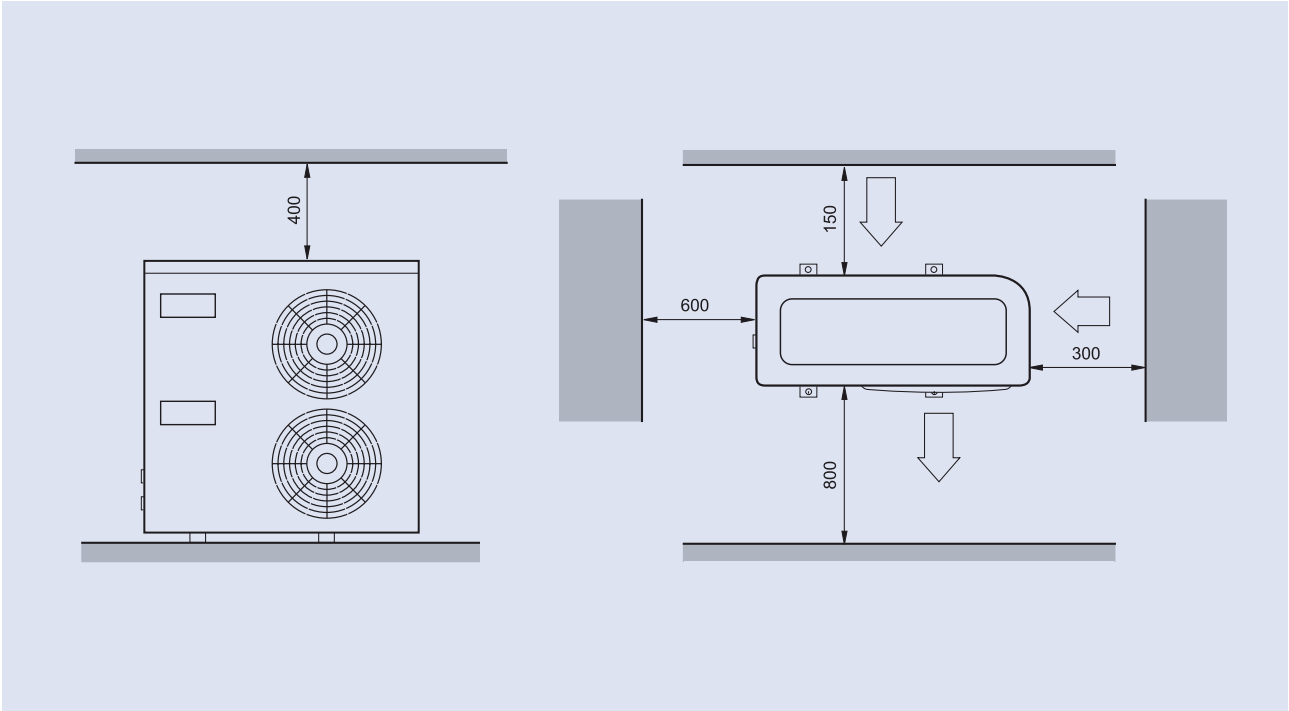

All dimensions in mm. Drawings not a scale.

Models YLCA-YLHA PLUS 20/27

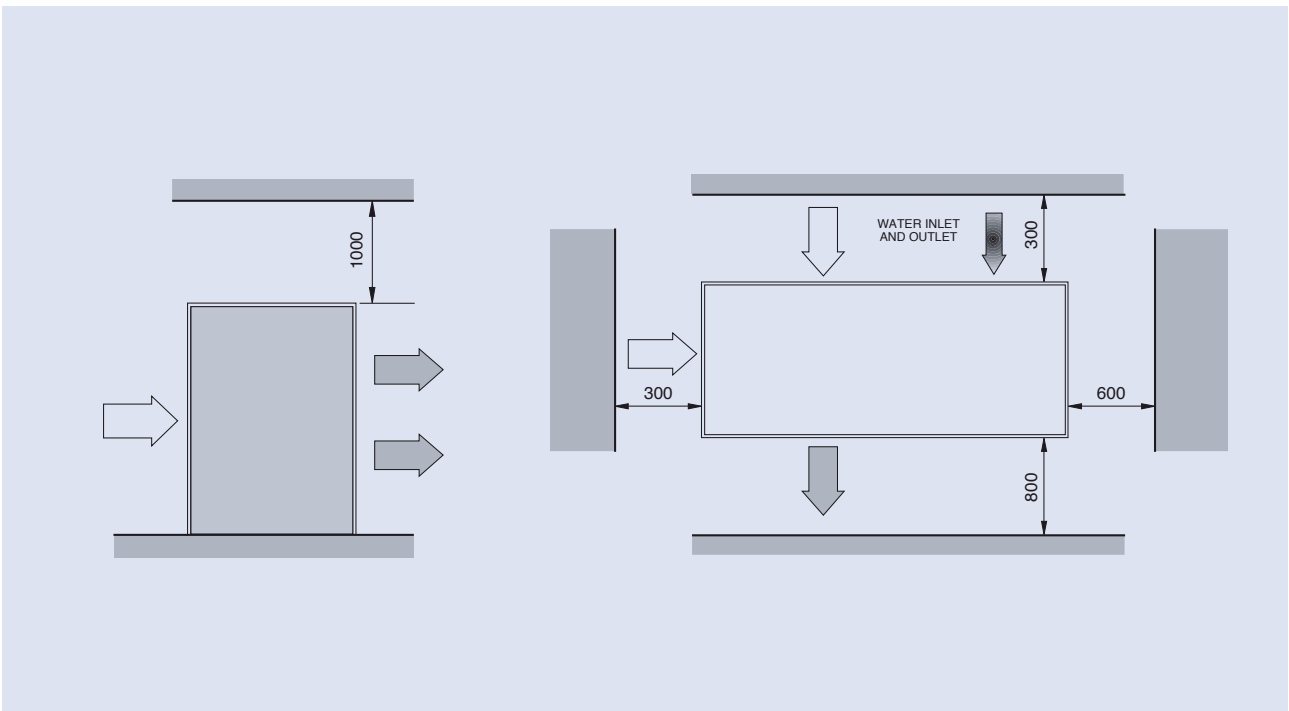

All dimensions in mm. Drawings not a scale.