



THERMOSTATS

USER GUIDE

Digital Thermostat - ARTTH001 ARTTH002 and ARTTH003
RoofTop and large split A/C systems



Table of Contents

	Page
1 - Specifications	3
1.1 - Product range.....	3
• ARTTH001 (DSL-610).....	3
• ARTTH002 (DSL-700).....	3
• ARTTH003 (DSL-600).....	3
1.2 - Technical data.....	3
1.3 - Power failures.....	3
1.4 - Temperature accuracy.....	3
2 - Installation	3
2.1 - Introduction.....	3
2.2 - Dimensions.....	3
2.3 - Location.....	3
2.4 - Installation and wiring.....	4
2.5 - Fixing the thermostat and cover to the installed base.....	4
2.6 - Dip Switch settings for ARTTH002 and ARTTH003.....	4
3 - Wiring	5
3.1 - Thermostat ARTTH001 terminals.....	5
3.2 - Thermostat ARTTH002 terminals.....	5
3.3 - Connections between thermostat and equipment terminals - ARTTH001.....	6
3.4 - Connections between thermostat and equipment terminals - ARTTH002.....	6
3.5 - Thermostat ARTTH003 terminals.....	6
3.6 - Connections between thermostat and equipment terminals - ARTTH003.....	6
4 - User controls	7
- Mode.....	7
- Cooling 	7
- Heating 	7
- Fan 	7
- DAY/NIGHT button 	7
- Celsius / Fahrenheit changeover.....	7
- Outdoor (odt) button.....	7
- Limited override.....	7
- Clock terminals (option).....	7
- Remote sensor (option).....	7
5 - Installing a remote sensor (ARTTH002 and ARTTH003 only)	8
- Single sensor installation.....	8
- Multiple sensor installation.....	8
- Using a duct sensor.....	8
- Troubleshooting.....	8
- Installation wiring diagrams.....	9

1 - Specifications

1.1 - Product range

• ARTTH001 (DSL-610)

This thermostat may be used with the following units:

- SOH/SIH 076-120 (with or without electrical heating)
- RTH 07→30 (with or without electrical heating)
- SCOH/SIH 076-120 (with or without electrical heating)

• ARTTH002 (DSL-700)

This thermostat may be used with the following units:

- D2IC 090→30 0A50 (with or without electrical heating)
- B2IH090→300 A50 (with or without single stage electrical heating)
- D2IG090→300 A50.

• ARTTH003 (DSL-600)

This thermostat may be used with the following units :

- SOH/SIH 150-240
- SCOH/SIH 150-240

1.3 - Power failures

Your thermostat employs the latest developments in solid state electronic technology.

One of the unique features of your thermostat is that there is no battery required to maintain your selected setpoints in the event of a power loss. The memory is unaffected by power failures of any duration.

When power is restored, the thermostat will continue operating as if the power had never been off.

1.2 - Technical data

Description	Values
Rated voltage	20-30 Vac, or DC 24V nominal
Rated A.C. current	0.50 Amps to 0.75 Amps continuous per output with surges to 3 Amp max
Rated D.C. current	0 Amps to 0.75 Amps continuous per output with surges to 3 Amp max
Control range	Heating: 5 to 30°C; 1°C steps Cooling: 16 to 40°C; 1°C steps
Thermostat measurement range	0 at 48°C
O.D.T. measurement range	-48 at 48°C
Control accuracy	± 0,5° C at 20°C
Minimum deadband	Between heating and cooling: 1°C

Note : This thermostat contains electronic circuitry replacing the conventional mechanical anticipator.

1.4 - Temperature accuracy

Full temperature accuracy will only be realised after the thermostat has been installed and powered for at least one hour.

2 - Installation

2.1 - Introduction

These thermostats use an adaptive control routine, based on fuzzy logic, to determine the heating or cooling load of the controlled space. The routine calculates load by evaluating recent room conditions, and room reactions to heating and cooling. This load is used to determine the cycle rate of the equipment, giving optimal control of the space.

2.2 - Dimensions

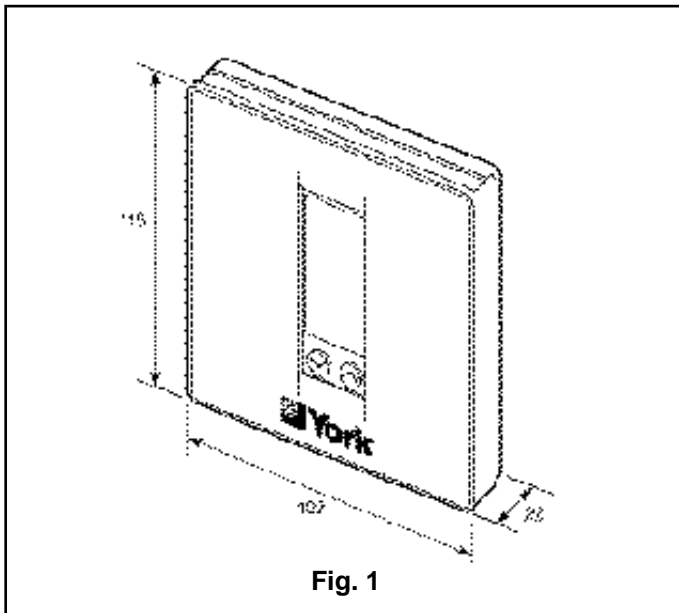

2.3 - Location

Locate thermostats as follows:

- On an inside wall, and approximately 1,5 m above the floor in a location with freely circulating air of an of average temperature.
- Away from direct sunlight or radiant heat, outside walls or behind doors, air discharge grills, stairwells, or outside doors
- Away from steam or water pipes, warm air stacks, unheated/uncooled areas, or sources of electrical interference.

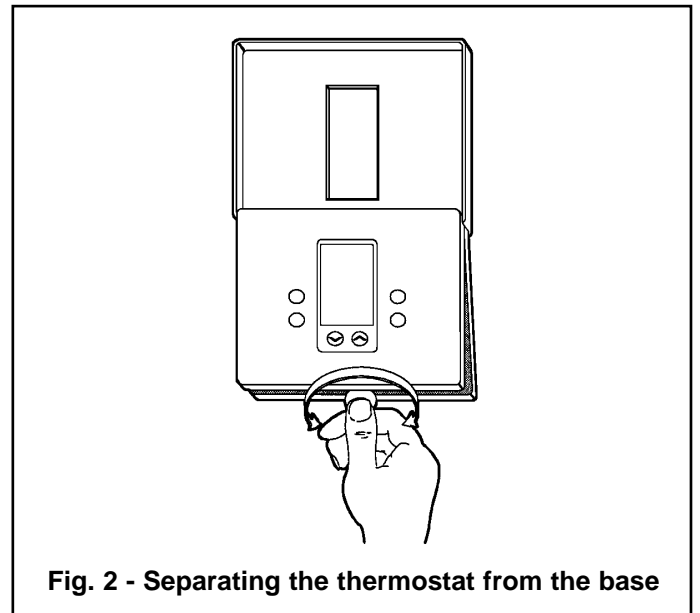

2 - Installation (cont'd)

2.4 - Installation and wiring

To install the thermostat:

1. Lift the thermostat cover and insert a flat blade screwdriver or coin into the slot located in the bottom center of the thermostat case and twist 1/4 turn. Grasp the base from the bottom two corners and separate from the thermostat. (See figure 2).
2. Swing the thermostat out from the bottom, and lift up and off the base. Place the rectangular opening in the base over the equipment control wires protruding from the wall and, using the base as a template, mark the location of the two mounting holes. No leveling is required.
3. Use the supplied anchors and screws for mounting on dry-wall or plaster. Drill two 5 mm holes at the marked locations, and tap nylon anchors flush to the wall surface and fasten. (See figure 3).
4. Connect the wires from the existing system to the thermostat terminals according to Wiring Tables 2 and 3. Push extra wire back into the wall. Wires must be flush to the plastic base.

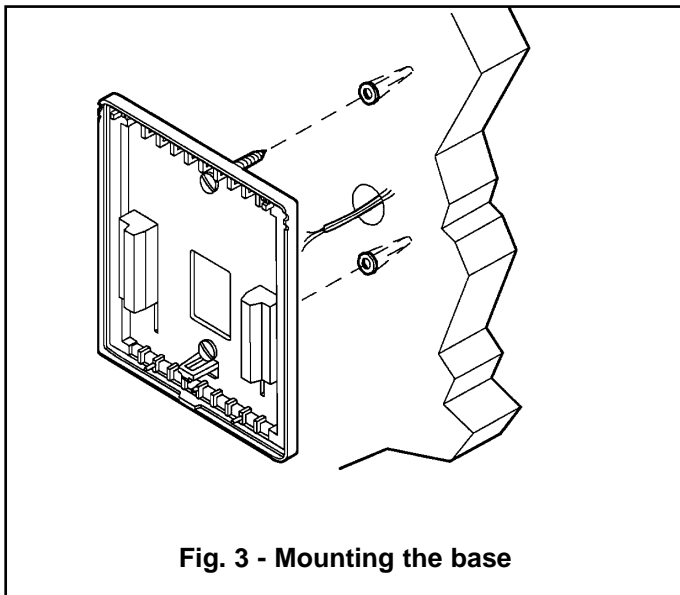

Fig. 3 - Mounting the base

2.6 - Dip Switch settings

These DIP switches are used on the models ARTTH002 and ARTTH003 only. Depending on model, there may be either 6 or 8 DIP switches.

The table below shows the description of the functions.

	Switch/Jumper selections	Description
1	Heat/Cool: 4 or 2 min. minimum on and off	Allows selection of minimum on/off time for compressors on heating and cooling.
2	Keyboard unlocked/locked	Allows user to disable buttons to prevent tampering
3	Fan immediate with heat call; or with plenum switch	Allows selection of immediate fan function with heat/cool call or function upon activation of plenum switch
4	Single stage Multistage	Allows selection of multiple stage heating or cooling
5	LED1 icon off/on	Optional selection: LCD icon comes on with LED1 (dirty filters)
6	LED2 icon off/on	Optional selection: LCD icon comes on with LED2 (compressor fault)

2.5 - Fixing the thermostat and cover to the installed based

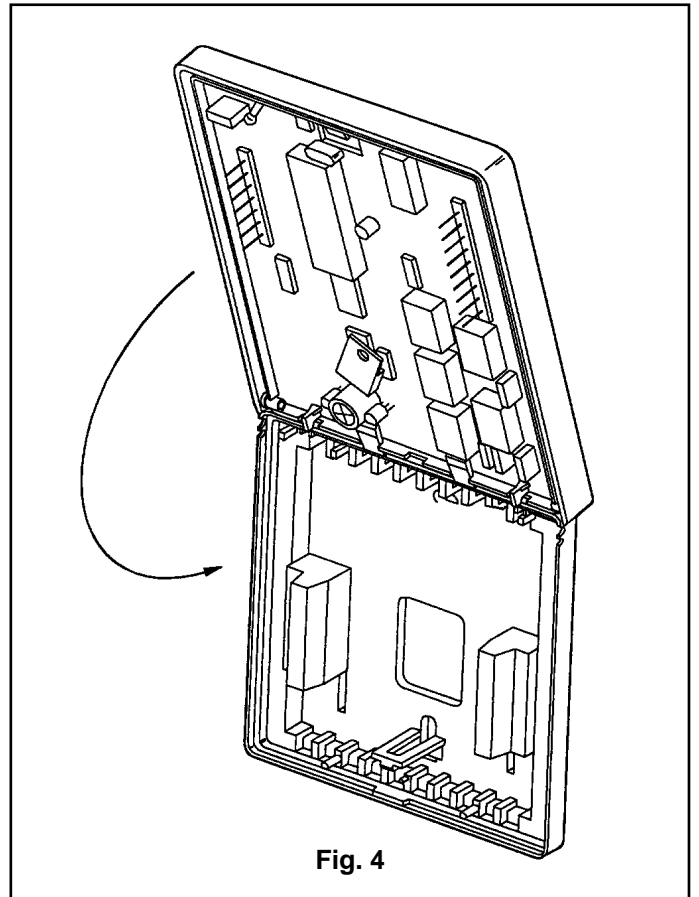

Fig. 4

1. Position the thermostat inside the cover and attach on the hinged tabs located at the top of the base.
2. Swing the thermostat and cover down, and press on the bottom centre edge until they snap in place. (See figure 4).

Factory setting

Heat/Cool : 4 minutes (minimum on)	1	NO	Heat/Cool: 2 minutes (minimum on)
Keyboard unlocked	2		Keyboard locked
Fan with heat/cool call	3		Fan with plenum switch
Single stage	4		Multistage
LED 1 icon off	5		LED 1 icon (dirty filters)
LED 2 icon off	6		LED 2 icon (Compressor fault)

2 - Installation (cont'd)

	Switch/Jumper selections	Description
1	Not used	Not used
2	Not used	Not used
3	Heat/Cool: 4 or 2 min. minimum on and off	Allows selection of minimum on/off time for compressors on heating and cooling.
4	Keyboard unlocked/locked	Allows user to disable buttons to prevent tampering
5	Compressor is not able to start immediately with a change to temps setpoint.	Compressor may start immediately with a change to temperature setpoint
6	Single stage Multistage	Allows selection of multiple stage heating or cooling
7	LED1 icon off/on	Optional selection: LCD icon comes on with LED1 (dirty filters)
8	LED2 icon off/on	Optional selection: LCD icon comes on with LED2 (compressor fault)

Normal	1	ON	Not used
Not used	2		Not used
Heat/Cool : 4 minutes (minimum on)	3		Heat/Cool: 2 minutes (minimum on)
Keyboard unlocked	4		Keyboard locked
Economy	5		Comfort
Single stage	6		Multistage
LED 1 icon off	7		LED 1 icon (dirty filters)
LED 2 icon off	8		LED 2 icon (Compressors fault)

3 - Wiring

3.1 - Thermostat ARTTH001 terminals

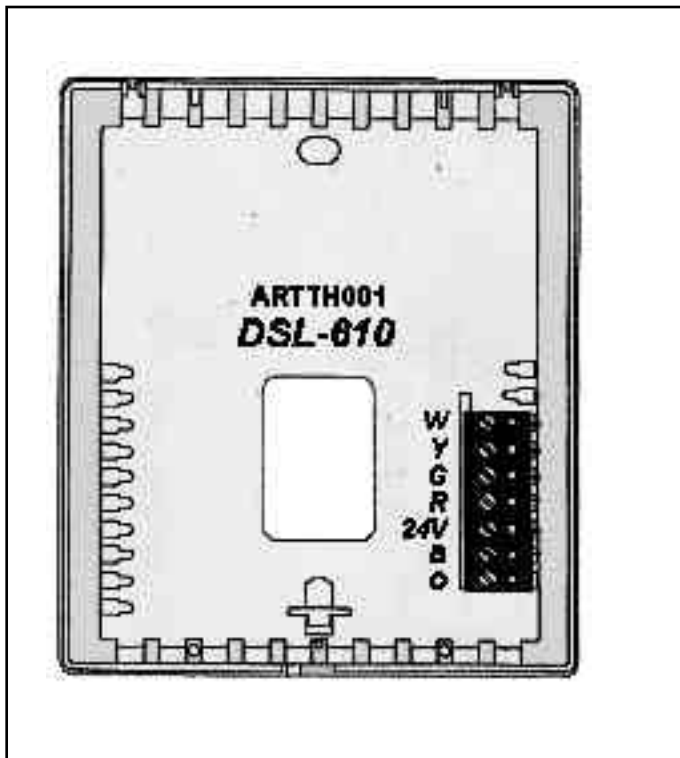

⚡ Jumper between 24V and R must be installed.

3.2 - Thermostat ARTTH002 terminals

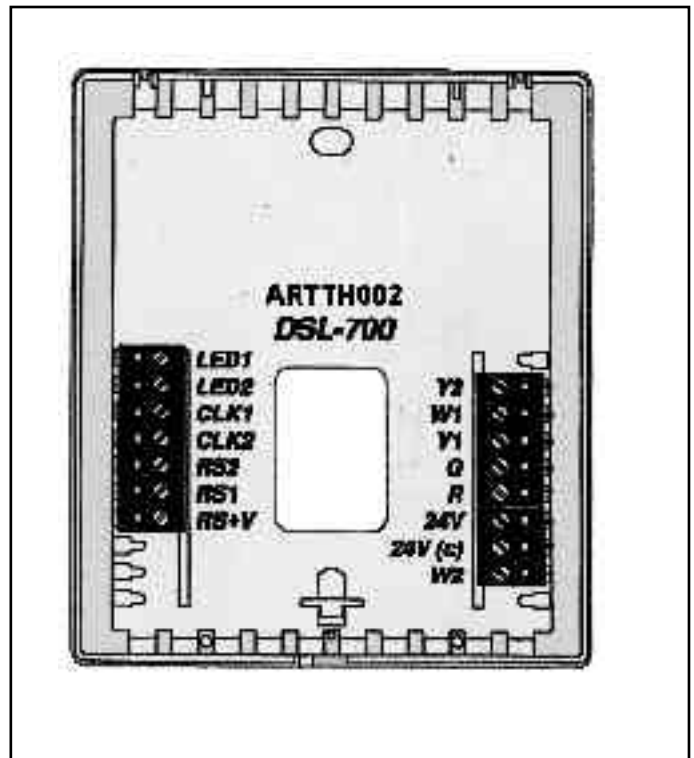

⚡ Jumper between 24V and R must be installed.

3 - Wiring (cont'd)

3.3 - Connections between thermostat and equipment terminals - ARTTH001

Thermostat terminal	Unit terminal	Description
W	W1	Auxiliary heat : Electric heaters
Y	Y1	Compressor: With a call for cooling or heating
G	G	Energises the fan circuit
R	R	24 VAC live
24V	24V	24 VAC live
B	B	24 VAC common
O	O	Energises 4-way valve in cooling mode

☛ Use only copper conductors only. Section > 1mm².

3.4 - Connections between thermostat and equipment terminals - ARTTH002

Thermostat terminal	Unit terminal	Description
Y2	Y2	Energises on a call for 2nd stage cool
W1	W1	Energises on a call for 1st stage heat
Y1	Y1	Energises on a call for 1st stage cool
G	G	Energises the fan circuit
R	R	Independent switching voltage
24V		24 VAC live
24V(C)	B	24 VAC common
W2	W2	Energises on a call for 2nd stage heat
LED1	optional	Dirty filters
LED2	X	Refrigerant circuit fault
CLK1	-	Use with external clock/timer for alternate setpoints
CLK2		
RS2	-	Remote Sensor (option).
RS1		
RS+V		

☛ Use only copper conductors only. Section > 1mm².

3.5 - Thermostat ARTTH003 terminals

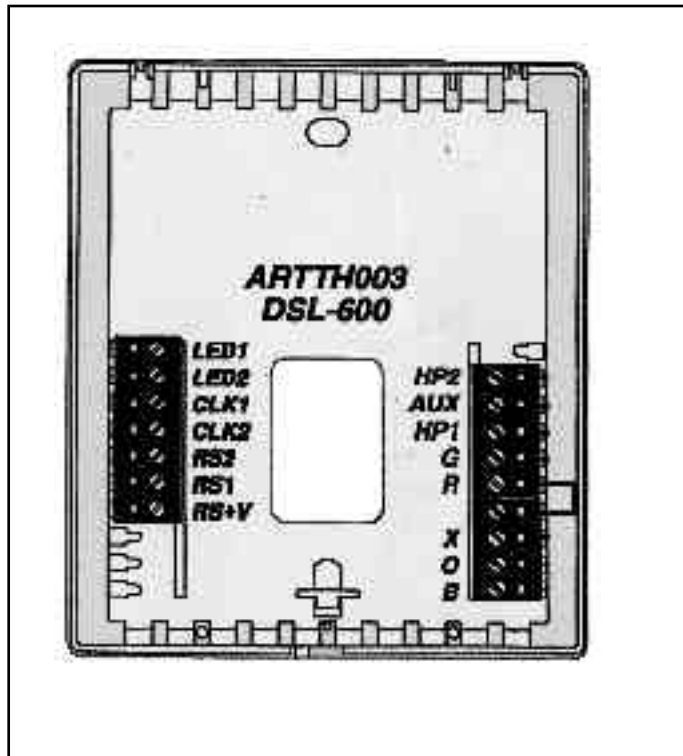

☛ Jumper must be installed.

3.7 - Connections between thermostat and equipment terminals - ARTTH003

Thermostat terminal	Unit terminal	Description
HP2/Y2	Y2	Energises compressor with call for 2nd stage heat or cool
AUX/W1	W1	Auxiliary heat : Electric heaters
HP1/Y1	Y1	Energises compressor with call for 1st stage heat or cool
G	G	Energises the fan circuit
R	R	24 VAC live
X/24V (C)	X	24 VAC common
0	0	Energises reversing valve in cooling mode
B	B*	Energises reversing valve in heating mode
LED1	optional	Dirty filters
LED2	LED2*	Refrigerant circuit fault
CLK1	-	Use with external clock/timer for alternate setpoints
CLK2		
RS2	-	Remote Sensor (option).
RS1		
RS+V		

☛ Use only copper conductors only. Section > 1mm².

* Only used on RTH-B, SOH-B and SCOH-B with Rol-on board.

4 - User controls

MODE

Select the desired mode of operation by pressing the MODE button repeatedly:

 - Controls cooling system only (the word "COOL" is displayed for 5 seconds).

 - Controls heating system only (the word "HEAT" is displayed for 5 seconds).

 - Controls both heating and cooling systems (auto changeover) (the word "AUTO" is displayed for 5 seconds).

OFF - Disables thermostat so equipment will not operate (the word "OFF" is displayed).



Avoid using the OFF mode during extremely cold weather to prevent damage from freezing.

 - Flashing - indicates Cool "ON"



 - Flashing - indicates Heat "ON"

E HT - Emergency heat

COOL

Select the temperature you want your equipment to maintain while in the cooling mode by momentarily pressing the  or  button. The temperature setpoint is displayed for 5 seconds after releasing the button.

HEAT

Select the temperature you want your equipment to maintain while in the heating mode by pressing and holding the  or  buttons. The temperature setpoint is displayed for 5 seconds after releasing the button.

FAN

The Fan will come on automatically when the system is operating, but there is no indication of this on the display. To select continuous Fan operation, press the FAN button and the display will show . This is recommended for electronic air cleaners or continuous ventilation requirements.



Note : The thermostat never allows less than 1°C difference between the heating and cooling setpoints.

AUTO



Selecting this mode of operation will control both heating and cooling functions. The thermostat will automatically switch from one to the other as determined by the selected setpoints in heating and cooling.

DAY/NIGHT BUTTON

Only available with ARTTH002 (DSL-700) and ARTTH003 (DSL-600)

When the thermostat is initially installed, the display will show the symbol  for your day temperature. By pressing the DAY / NIGHT button or closing the CLK1 and CLK2 terminals on the back of the thermostat (installer connected) you may select an alternate or night  temperature. (The thermostat will remember this setpoint). Simply press the Day / Night button to alternate between temperature settings.

CELSIUS / FAHRENHEIT

Simultaneously press  and  to switch between °F and °C temperature display.



"Outdoor" BUTTON

Only available with ARTTH002 (DSL700) and ARTTH003 (DSL-600)

When the outdoor temperature sensor option is connected to your thermostat, you can display the current outdoor temperature by pressing the outdoor button. If the option is not connected, the thermostat will display "--".

LIMITED OVERRIDE

Only available with ARTTH002 (DSL700) and ARTTH003 (DSL-600)

When the keyboard is locked (switch #2 "ON"), the user may override the temperature setpoint for 1 hour by pressing either the  or  button. The range of temperature override is +/- 3 °C from the programmed daytime setpoint.

CLOCK TERMINALS (OPTION)

CLK1 - CLK2

Only available with ARTTH002 (DSL700) and ARTTH003 (DSL-600)

Your thermostat is equipped with Remote Clock Terminals. By connecting a remote clock/ timer. The thermostat can be alternated between the Day/Night setpoints automatically.

REMOTE SENSOR (OPTION)

RS1 - RS2 - RS+V

Only available with ARTTH002 (DSL700) and ARTTH003 (DSL-600)

These thermostats are designed to accept the Electronic Remote Sensor which will allow you to locate your thermostat in an area away from view.

5 - Installing a remote sensor

INSTALLING an ALSRS001S REMOTE Sensor, ALSDS001 duct sensor for ARTTH002 (DSL-700) and ARTTH003 (DSL-600) only.

Introduction :

The indoor sensor is designed to sense the air temperature at a remote location and send this information by digital communications to the thermostat. Any number of sensors up to six can be connected together to provide temperature averaging. The sensor can also be modified for use with a duct sensor.

Single Sensor Installation :

1 - Install the ARTTH002 (DSL-700) or ARTTH003 (DSL-600) thermostat. Check that the thermostat is operating. (Display shows the correct temperature.)

CAUTION : Remove the thermostat from the subbase while wiring the sensor to avoid damage from live wires. This is important.

2 - Install non-shielded 3 conductor wire from the thermostat to the remote sensor location. Maximum distance is (90m).

3 - Open the sensor case by depressing the button on the bottom edge of the case until the latch releases. Remove the cover by pulling it out and up at the bottom.

4 - Remove the board from the subbase by pulling back the latch that holds it at the center bottom.

5 - Use the sensor subbase as a template to mark the mounting hole locations on the wall. Drill size for the wall anchors is 6 mm. Mount the subbase over the wires coming out of the wall using the two screws and anchors provided. The angled corner on the subbase should be in the bottom right.

6 - Snap the board back into the subbase. Check to be sure that the latch holds the board properly. Check that the thermistor (sensor element) is positioned under the holes in the cover but not touching the cover or subbase.

7 - Strip 6 mm of insulation from the three wires at the Remote Sensor. Install the wires in the terminals labelled RS2, RS+V and RS1. Push any extra wire back into the wall cavity. Seal the hole in the wall around the cable to eliminate any draft that might affect the sensor. Refer to Figure 1.)

8 - Note the wire colour going to each terminal. The order of the wires on the thermostat is not the same as the sensor.

9 - Connect the wires on the thermostat subbase to the terminals labelled RS2, RS1 and RS+V. Make sure that each terminal on the sensor is wired to the terminal with the same name on the thermostat.

10 - Mount the thermostat on the subbase and check to be sure that it is showing the temperature.

11 - Re-install the cover on the remote sensor by hooking it on the top and snapping the bottom into place.

Using Multiple Sensors for Temperature Averaging :

Any number from two to six sensors may be connected together to provide temperature averaging in a large area or several zones being controlled by the same system. Maximum dis-

tance between any 2 sensors is 300 ft. (90m).

1 - Wire the first sensor using the single sensor instructions.

2 - CAUTION : Make sure that there is no power to the sensors by removing the thermostat from the subbase.

3 - Connect wires to each additional sensor in the following manner. An outdoor sensor can also be connected in an location in the chain. (Refer to Figure 2 also.)

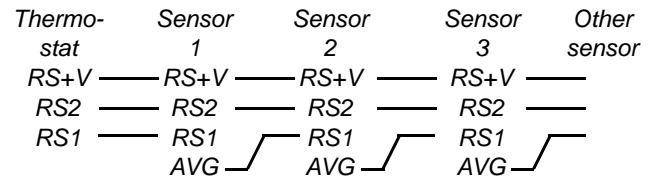

4 - Replace the thermostat on the subbase. Check for proper operation of each sensor by connecting a jumper between terminals 1 and 2. This shorts out the thermistor. The displayed temperature will go up several degrees if the sensor is properly installed. Repeat for each sensor.

Using a Duct Sensor :

The ALSRS001S sensor and ARTTH002/003 thermostats are designed to sense air temperature in a room. The fast moving air in a duct has small but rapid changes in temperature. This will affect the control algorithm of the thermostat. For better control, it is recommended that the air temperature is sensed in the room.

1 - Install the indoor sensor using the Single Sensor instructions.

2 - Clip the thermistor from the Indoor sensor with wire cutters as shown in Figure 3.

3 - Install the duct sensor in the return air duct according to the instructions supplied with it. Connect the two wires from the duct sensor to terminals 1 and 2 of the indoor sensor. If shielded cable was required because of a long distance to the sensor box, connect the shield to terminal 2 also.

Troubleshooting :

Thermostat has no display : Check wiring between thermostat and sensor. Incorrect wiring can damage the thermostat, transformer or blow a fuse. Check 24VAC supply.

Thermostat reads "AC" : 24VAC power is disconnected.

Not sure if display is showing local or remote temperature : Breathe on the wall near the bottom left corner of the thermostat. Temperature will go up for a few seconds if sensing locally.

Thermostat displays very high temperature : Wires on sensor element are shorted together. Separate them.

Thermostat displays very low temperature : Check wiring of probe or duct sensor. Sensor element is not connected to board or is broken.

5 - Installing a remote sensor (cont'd)

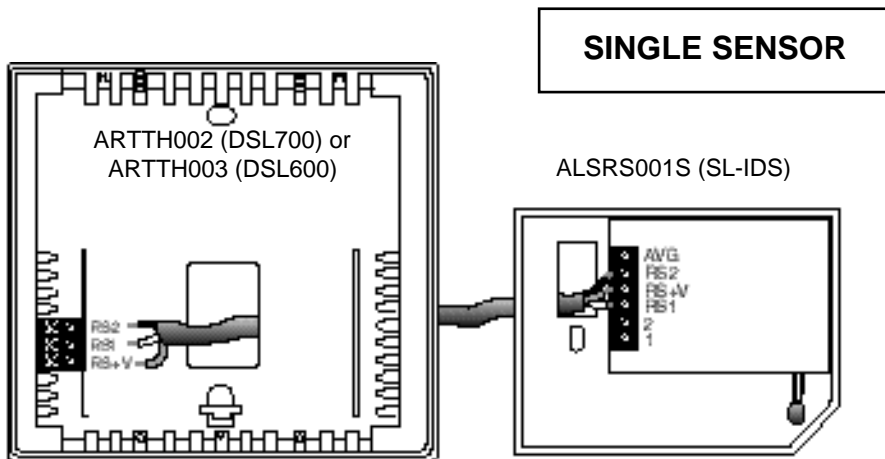

FIGURE 1

PLEASE NOTE :

- Max cable length between any 2 units : 300ft. (90m)
- Max. number of indoor sensors in daisy chain : 6
- Max. number of duct sensors in daisy chain : 1

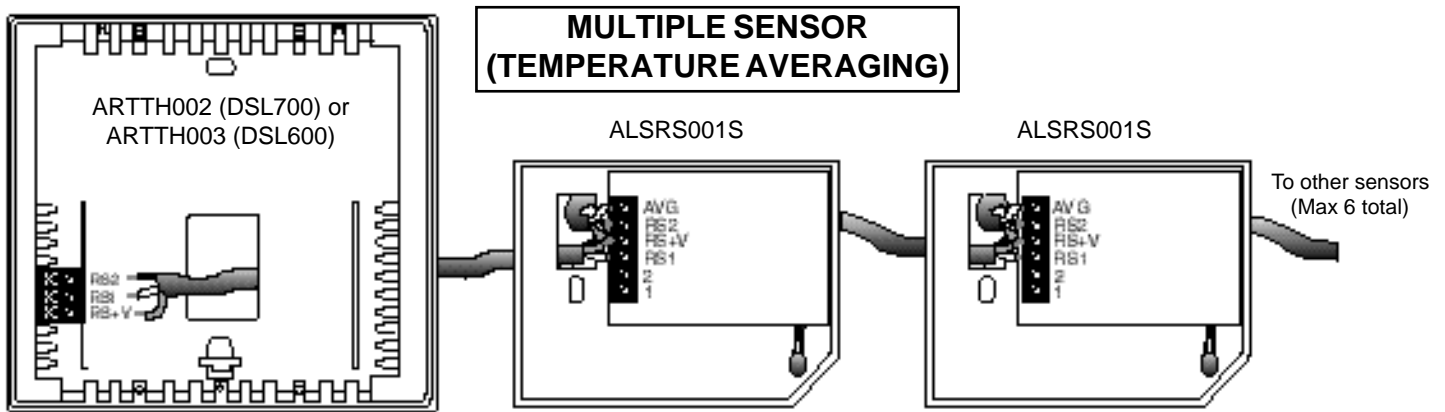

FIGURE 2

INSTALLING AN ALSD5001S DUCT SENSOR

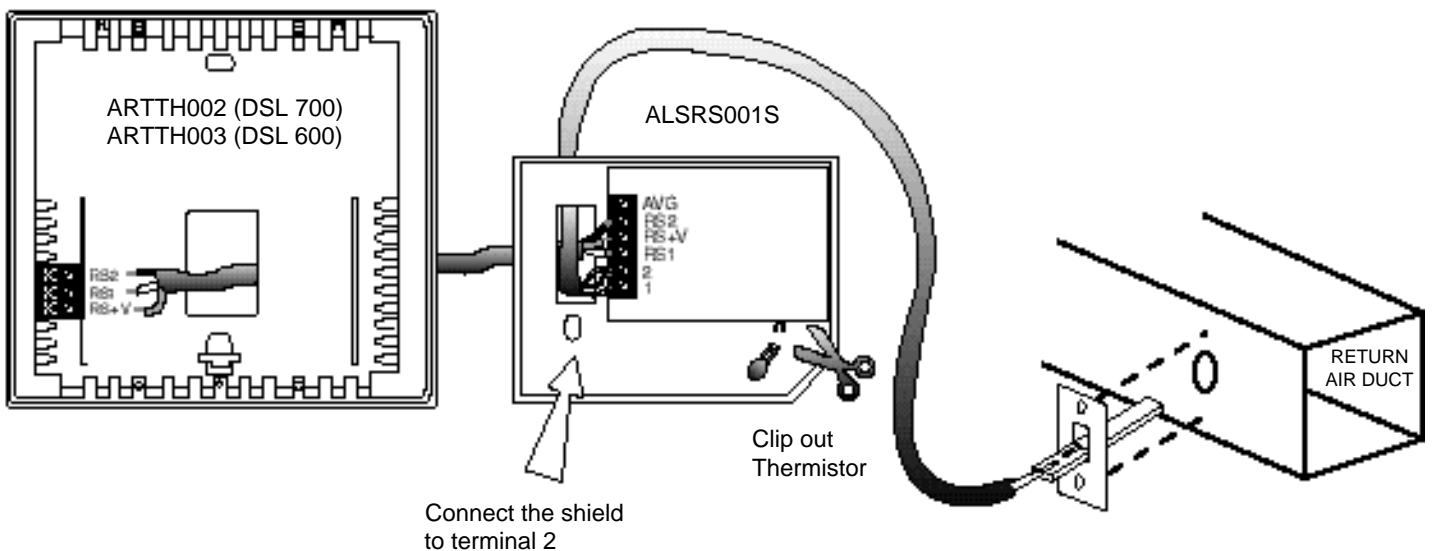

FIGURE 3

