

---

**Compact Horizontal  
Air-Air Heat Pump  
Model RTH-07 to 30 B/G**

---



Ref.: TRTHBBE2

**Technical information**



Clima Roca York S.L. is participating in the EUROVENT Certification Program. Products are as listed in the EUROVENT Directory of Certified Products, in the program AC1, AC2 and AC3.

---

<b>Index</b>	<b>Page</b>	<b>Page</b>
<b>General information</b>	<b>3</b>	<b>Installation of accessories</b>
- General description	3	- Tray heater
- Nomenclature	3	- Electric heating
		- Indoor coil probe
<b>Technical specifications</b>	<b>3</b>	<b>Malfunctions</b>
- Mechanical specifications	3 - 4	- Indoor fan thermal switch
- Physical data	5	- High and low pressure switch
- Limits of Use	5	- Electric heating thermal switch (accessory)
- General dimensions	6 - 7	- Thermostat errors
- Nominal capacities	8	- Protection for defrost cycles
- Test conditions	8	- Protection for temperature
- Correcting factors	8	- Open or short circuit of the outdoor or indoor liquid probe
- Nominal flows	8	- Open or short circuit of discharge probe
- Sensible cooling capacities	9 - 10	- Signalling
- Indoor and outdoor fan services	11	- Incidents
- Electrical characteristics	12	- Failures (lockouts)
		- Reset
<b>Operation</b>	<b>13</b>	<b>Wiring diagrams</b>
- Indoor fan	13	
- Outdoor fan	13	
- Four-way valve	13	
- Compressor	13	
- Defrost	13	
- Start-up	13	
- End	13	
<b>Test button and LEDs</b>	<b>13</b>	<b>Accessories</b>
<b>Configuration</b>	<b>13</b>	<b>Duct electric heaters for RTC/RTH-07 to 30 B/G</b>
- Microswitches	14	- Technical specifications
- Configuration of switches	14	- General dimensions
- Configuration of accessories	14	- General characteristics
		- Dimensions with packing and weights
		- Installation
		- Heater location
		- Wiring diagrams

# General information

## General description

The RTH model heat pumps are compact horizontal units, condensed by air, that allow air conditioning, both in winter as well as in summer, by inverting their operating cycle. They can be installed either indoors or outdoors, and the fans are of the centrifugal type, and thus accept air ducts.

## Nomenclature

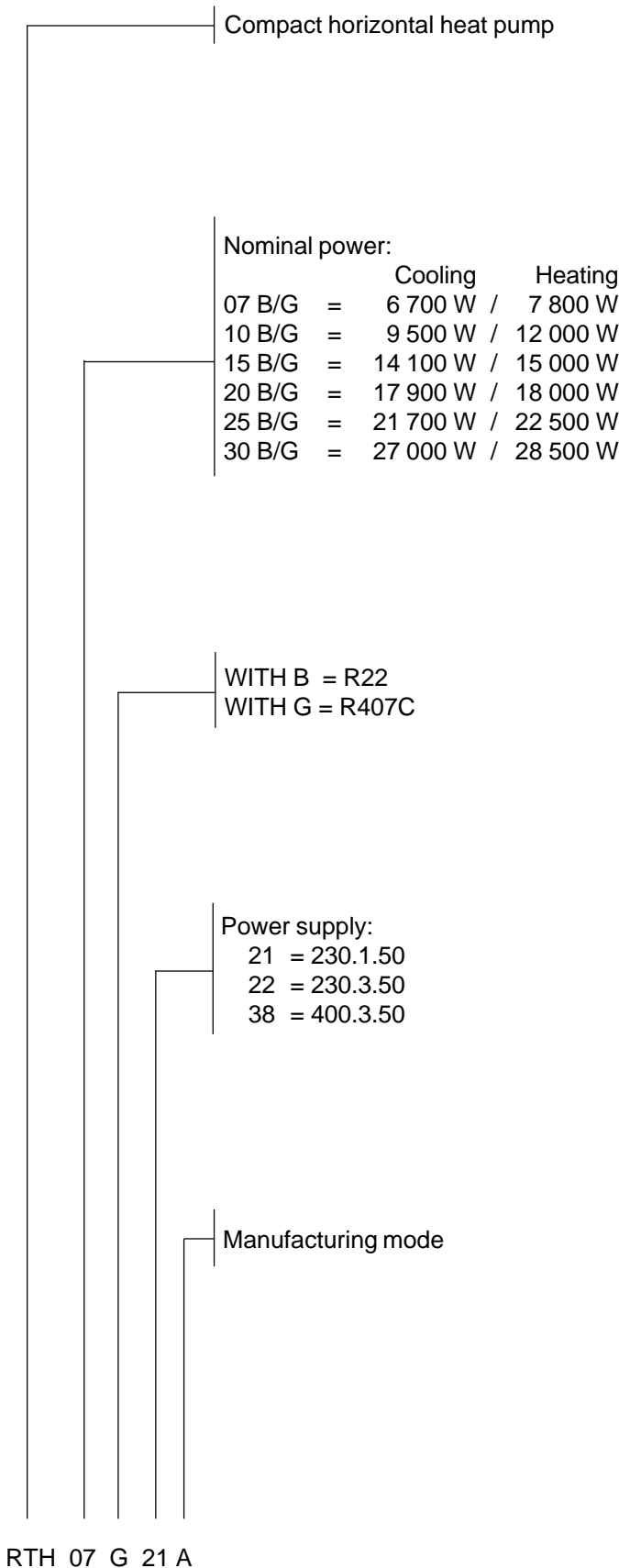

# Technical specifications

## Mechanical specifications

### Compressor

Of the vertical hermetic alternative type, mounted on shock absorbers and with internal motor protection. Includes an electric heater for heating the oil sump, which makes start-ups easier and avoids oil leaking from the compressor.

### Coils

With a large surface, made of grooved copper tubing and notched aluminium fins.

### Fans

Centrifugal with directly fitted motor or belt and pulley drive, depending upon the model. Have sufficient pressure for the installation of optional ducts and accessories.

### Casing

Made of galvanised aluminium steel sheeting and finished with oven-polymerised powdered paint, for outdoor installation. The interior is lined with an insulation coating so as to avoid condensation and reduce noise levels. These units include galvanised sheeting trays with their corresponding drains for collecting condensates from the coils.

### Cooling circuit

Made of welded copper tubing. The units are supplied with their optimum refrigerant loads and having gone through maximum pressure and air tightness tests. Both in the interior as well as exterior sections, the expansion of the refrigerant is carried out by means of calibrated and distributed holes. The circuit includes: four-way valve, suction accumulator, high and low pressure switches and suction and discharge pressure collectors.

### Refrigerant

These units are manufactured in versions for R-22 (RTH-B) and R-407C (RTH-G).

### Electric panel

Accessible directly from the exterior. Includes: connecting strip, protectors, electronic board and probes, power supply contactors, operating relay and transformer. In compliance with European standards in force.

### Electric heater (optional)

Of the uncovered wire type for quick heat dispersion, avoiding temperature inertia that could affect components, equipped with thermal contacts and protectors, automatic switch and manual reset.

### Thermostat

The RTH-07 to 30 units include, as standard equipment, the electronic ARTTH001S thermostat. Nevertheless, upon request and as an accessory, you can also use the one-stage digital electronic thermostats ARTTH003S, which can be configured for one stage, and with the possibility of communication.

To connect the thermostat to the Rolon board, 10x0.22mm<sup>2</sup> screened communication cable should be used.

#### ARTTH001S thermostat

Of the digital electronic type, 24 Vac. For controlling one cooling and one heating stage. Designed to provide precision control of the ambient temperature and give graphic information about the operating mode of the unit. This is a Proportional-

Differential-Integral response control in accordance with the differential between the programmed temperature set point and the ambient temperature. It responds varying the on/off cycles between 3 and 7.5 cycles per hour. Allows AUTO/ON operation of the indoor fan. See Operating and Maintenance Instructions.

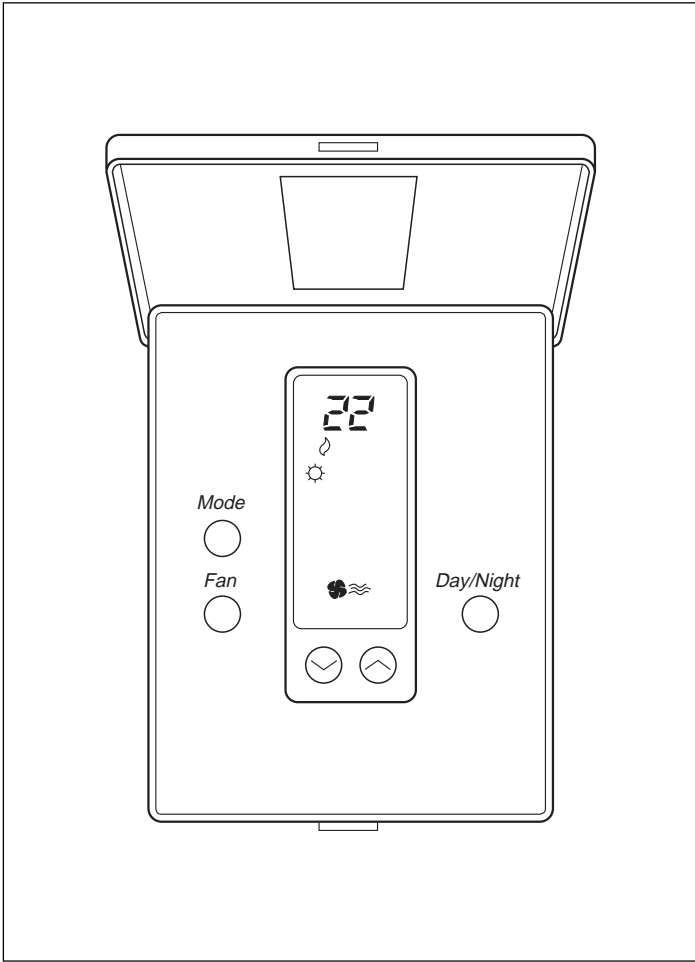

*ARTTH003S thermostat*

Of the digital electronic type. For controlling two cooling and two heating stages. Can be configured for one cooling and one heating stage. Designed to provide precision control of the ambient temperature and give graphic information about the operating mode of the unit. This is a Proportional-Differential-Integral response control in accordance with the differential between the programmed temperature set point and the ambient temperature. Allows communication with a PC and AUTO/ON operation of the indoor fan. See Operating and Maintenance Instructions.



## Physical data

Model		RTH-07 B/G	RTH-10 B/G	RTH-15 B/G	RTH-20 B/G	RTH-25 B/G	RTH-30 B/G	
Compressor	Amount	1						
	Nominal power	kW	2.7	3.2	4.7	5.2	7.9	9.2
	Power supply	V.ph.Hz.	230.1.50	230.3.50 400.3.50	230.3.50 400.3.50	230.3.50 400.3.50	230.3.50 400.3.50	230.3.50 400.3.50
Outdoor coil	Amount	1						
	Tubing depth x height		5 x 18	5 x 21	5 x 21	5 x 21	5 x 24	5 x 24
	Front area	m <sup>2</sup>	0.32	0.41	0.51	0.65	0.71	0.87
	Tubing diameter	3/8"						
Indoor coil	Amount	1						
	Tubing depth x height		3 x 18	4 x 21	4 x 21	4 x 21	3 x 24	4 x 24
	Front area	m <sup>2</sup>	0.22	0.25	0.37	0.47	0.61	0.73
	Tubing diameter	3/8"						
Outdoor fan motor	Amount	1						(1)
	Turbine diameter	mm	270	320	320	320	320	320
	Turbine width	mm	270	240	240	320	240	320
	Nominal power	kW	0.58	0.99	0.99	1.1	1.1	1.5
	Motor nominal r.p.m.		900	900	900	900	900	1 420
	Power supply	V.ph.Hz.	230.1.50	230.1.50	230.1.50	230.3.50 400.3.50	230.3.50 400.3.50	230.3.50 400.3.50
Indoor fan motor	Amount	1						(1)
	Turbine diameter	mm	240	270	320	320	320	320
	Turbine width	mm	240	200	240	240	240	320
	Nominal power	kW	0.38	0.54	0.95	0.99	1.1	1.1
	motor nominal r.p.m.		900	900	900	900	1 410	1 410
	Power supply	V.ph.Hz.	230.1.50	230.1.50	230.1.50	230.3.50 400.3.50	230.3.50 400.3.50	230.3.50 400.3.50
Refrigerant load R-22/R-407C	kg	2.25/1.93	3.00/3.00	3.5/3.5	4.35/5.8	5.9/5.9	6.3/6.1	
Dimensions with packing	mm	1140x1200x610	1190x1250x690	1350x1410x690	1670x1610x990	1760x1800x780	1810x2160x780	
Weight	Nett	kg	163	190	224	275/285	350	412
	Gross	kg	174	205	240	295/305	370	452

(1) Belt drive

## Limits of Use

Voltage limits <sup>a</sup>				Air intake temperature to outdoor coil DB				Air intake temperature to indoor coil			
Nominal 230 V		Nominal 400 V		Operating cycle				Operating cycle			
				Minimum °C		Maximum °C		Minimum °C		Maximum °C	
Minimum	Maximum	Minimum	Maximum	Cool	Heat	Cool	Heat	Cool WB	Heat DB	Cool WB	Heat DB
198	254	342	436	19	-20 <sub>(1)</sub>	46	24	14	10 <sub>(2)</sub>	22	25

**Notes:** WB = Wet bulb. DB = Dry bulb. (1) At below -20°C, only the emergency electric heater (optional) remains operative. (2) This equipment can operate for a short period of time at a temperature below 10°C so as to increase the air temperature within the conditioned space to 10°C.

# General dimensions mm

## RTH-07 B/G, 10 B/G, 15 B/G and 20 B/G

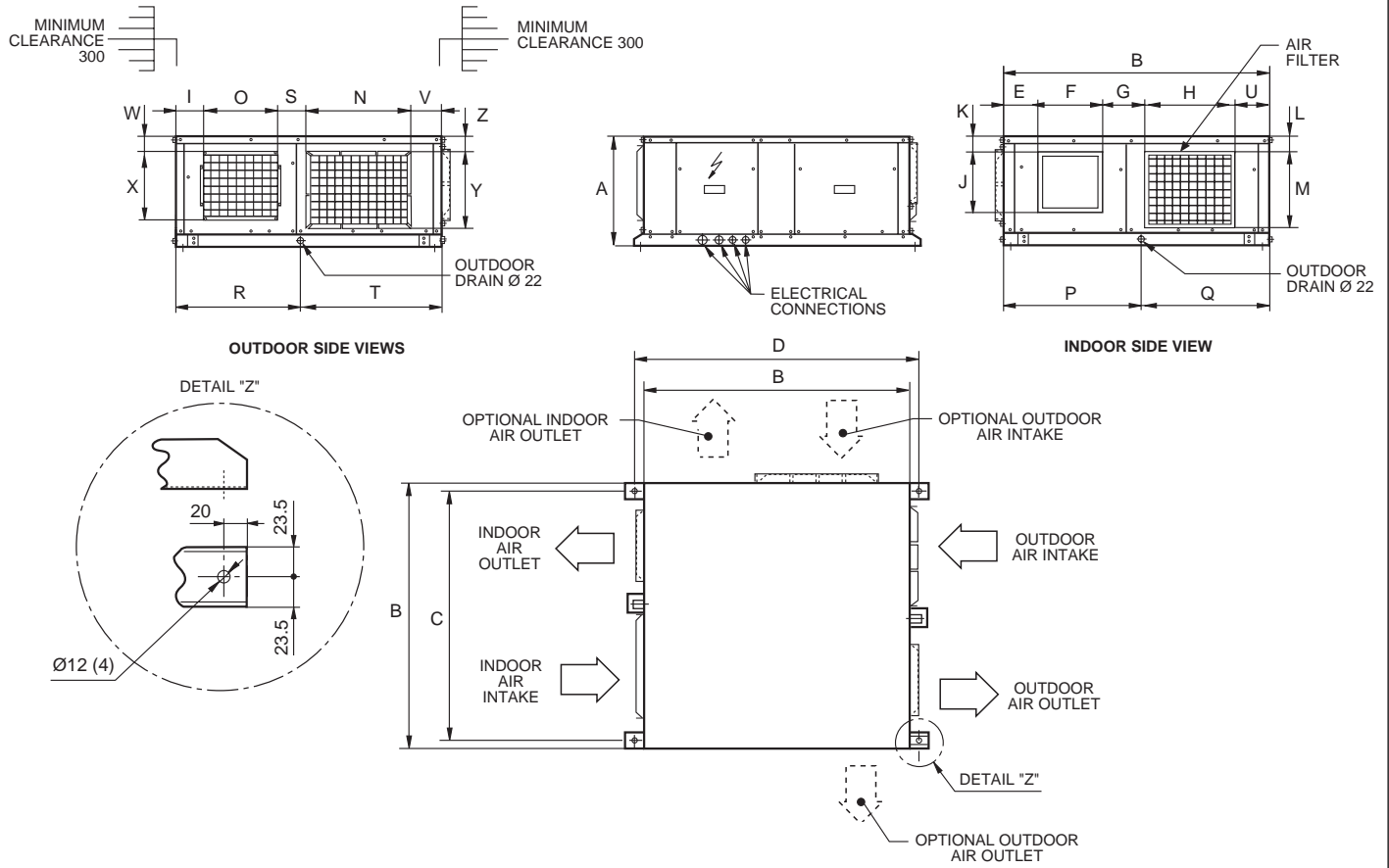

**Note:**

1- The solid arrows indicate the standard air intakes and outlets. The dotted arrows are the intakes and outlets that can be obtained at job site.

Model	A	B	C	D	E	F	G	H	I	J	K	L	M	N	O	P	Q	R	S	T	U	V	W	X	Y	Z
<b>RTH-07 B/G</b>	478	1100	1055	1150	117	302	136	425	82	262	72.5	60	300	425	347	600	500	602	165	500	120	82	18	305	342	40
<b>RTH-10 B/G</b>	555	1150	1105	1200	130	270	210	375	82	294	101	50	420	404	323	600	550	615	220	537	165	117	20	353	430	40
<b>RTH-15 B/G</b>	555	1310	1265	1360	140	316	154	600	87	346	24	45	425	554	323	600	710	590	225	720	100	121	20	353	430	40
<b>RTH-20 B/G</b>	585	1570	1525	1620	140	316	210	750	85	346	54	80	420	770	407	622	950	697	206	875	154	102	50	353	430	70

# General dimensions mm

## RTH-25 B/G and 30 B/G

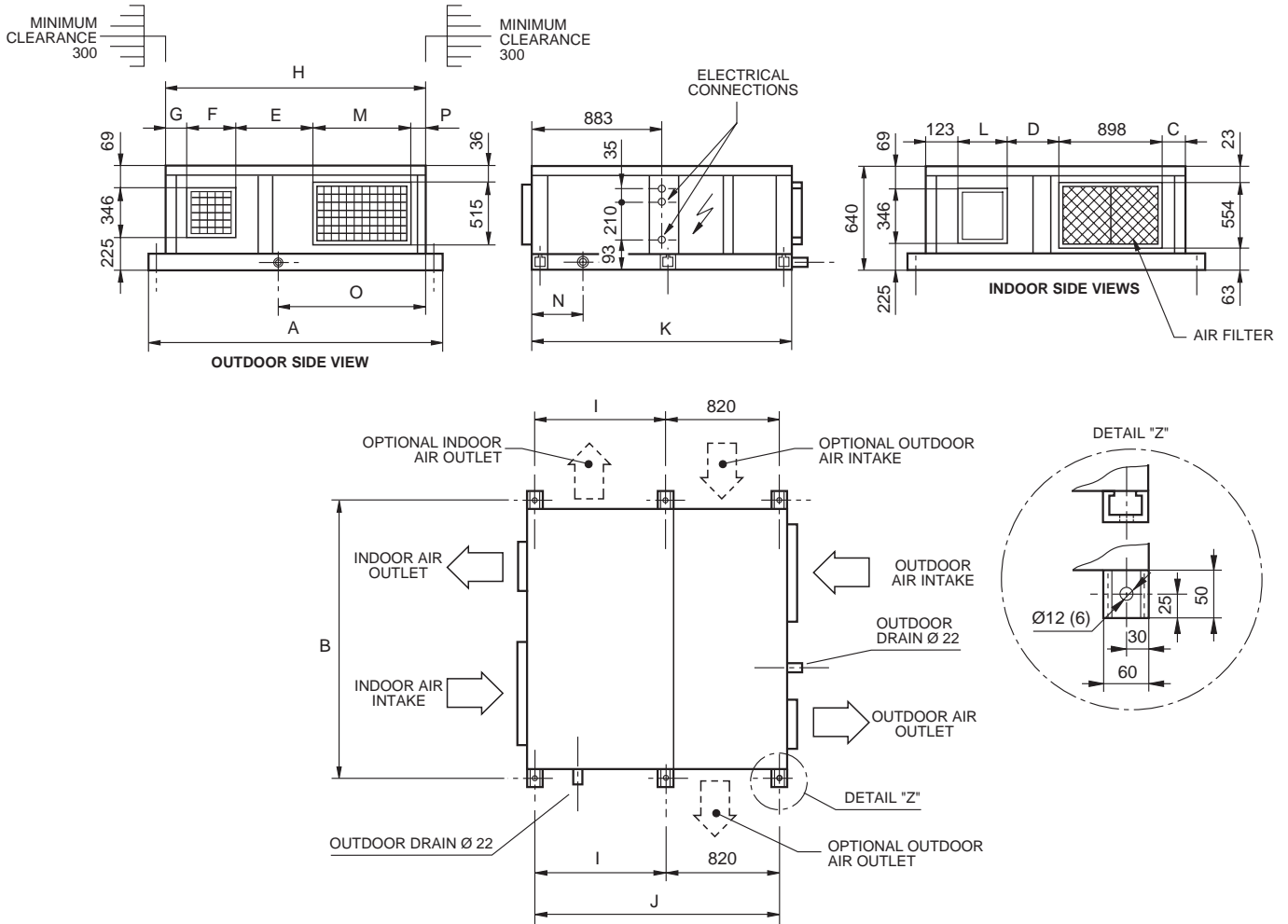

**Note:**

1- The solid arrows indicate the standard air intakes and outlets. The dotted arrows are the intakes and outlets that can be obtained at job site.

Model	A	B	C	D	E	F	G	H	I	J	K	L	M	N	O	P
<b>RTH-25 B/G</b>	1 750	1 700	81	233	442	315	133	1 650	870	1 690	1 750	315	667	348	1 145	93
<b>RTH-30 B/G</b>	2 150	2 100	130	499	648	400	138	2 050	890	1 710	1 770	400	732	368	1 495	132

## Nominal capacities

Unit	Summer		Winter	
	Cooling capacity W	Consumption W	Heating capacity W	Consumption W
<b>RTH-07 B/G</b>	6 700	3 600	7 800	2 800
<b>RTH-10 B/G</b>	9 500	4 600	12 000	3 700
<b>RTH-15 B/G</b>	14 100	6 900	15 000	5 000
<b>RTH-20 B/G</b>	17 900	7 600	18 000	6 900
<b>RTH-25 B/G</b>	21 700	10 400	22 500	7 500
<b>RTH-30 B/G</b>	27 000	12 300	28 500	10 900

## Test conditions

Voltage	Summer				Winter			
	Outdoor temp. °C		Indoor temp. °C		Outdoor temp. °C		Indoor temp. °C	
	DB	WB	DB	WB	DB	WB	DB	WB
230 or 400	35	24	27	19	7	6	20	12

## Correcting factors

### Correcting factors for cooling capacities

Correcting factors for cooling capacities in accordance with indoor and outdoor temperatures.

Indoor air intake temperature, °C WB	Outdoor intake air temperature, °C DB					
	19	25	30	35	40	46
23	-	1.20	1.15	1.11	1.06	1
19	1.10	1.08	1.04	1	0.96	0.90
14	0.88	0.86	0.84	0.82	0.79	0.74

**Note:** For indoor unit intake temperatures DB between 21 and 32°C. WB - wet bulb. DB - dry bulb.

Cooling capacity correcting factors for flows that differ from the nominal flows of the indoor coil.

Flow %	80	90	100	110	120	130
Total capacity	0.960	0.980	1	1.016	1.032	1.046
Sensible capacity	0.945	0.973	1	1.038	1.075	1.118
Comp. absorbed power	0.980	0.990	1	1.009	1.017	1.025

Correction of the real temperature of air intake of the outdoor coil for flows that differ from the nominal values.

Flow %	70	80	90	100	110	120	130
Correction in °C on real temperature of air intake of outdoor coil	5	3	1.5	0	-1	-2	-2.5

### Correcting factors for the heating capacities

Indoor air intake temperature, °C DB	Outdoor air intake temperature, °C WB				
	14	10	6	0	-8
23	1.20	1.04	0.96	0.77	0.58
20	1.25	1.10	1.00	0.80	0.69
17	1.30	1.13	1.04	0.83	0.63

Correction of the real temperature of intake air to the outdoor unit coil for flows that differ from the nominal values.

Flow %	70	80	90	100	110	120	130
Correction in °C on real temperature of air intake of outdoor coil	-2	-1.5	-0.5	0	0.5	1	1.2

## Nominal flows

The cooling and heating capacities that appear in the corresponding tables are valid for the following nominal flows:

Model	Nominal flow indoor fan m³/h	Nominal pressure available Pa	Nominal flow outdoor fan m³/h	Nominal pressure available Pa
<b>RTH-07 B/G</b>	1970	25	2 380	50
<b>RTH-10 B/G</b>	2 430	37	3 450	50
<b>RTH-15 B/G</b>	4 030	50	4 270	50
<b>RTH-20 B/G</b>	4 485	50	5 250	50
<b>RTH-25 B/G</b>	5 000	62	5 250	50
<b>RTH-30 B/G</b>	5 850	62	6 400	50

For other flows, apply the correcting factors of the corresponding table.



## Sensible cooling capacities

Model	Dry temperature, outdoor air °C (DB)	Humid temperature, air intake, °C (WB)	Total capacity	Sensible capacity (W)				Compressor absorbed power
				Dry intake air temperature to coil, °C (DB)				
				22	24	27	29	
			W	W	W	W	W	kW
<b>RTH-07 B/G</b>	25	22	8 040	2 397	3 502	5 158	6 264	2.27
		19	7 236	4 114	5 218	6 875	7 236	2.38
		17	6 700	5 243	6 348	6 700	6 700	2.49
	35	22	7 437	2 199	3 303	4 960	6 064	2.57
		19	6 700	3 916	5 021	6 677	6 700	2.71
		17	6 164	4 531	5 636	6 164	6 164	2.84
	45	22	6 700	1 978	3 082	4 739	5 843	2.98
		19	6 030	3 691	4 795	6 030	6 030	3.11
		17	5 494	4 769	5 494	5 494	5 494	3.25
<b>RTH-10 B/G</b>	25	22	11 400	3 422	4 897	7 110	8 587	2.72
		19	10 260	5 715	7 190	9 403	10 260	2.85
		17	9 500	7 224	8 698	9 500	9 500	2.97
	35	22	10 545	3 138	4 613	6 825	8 300	3.07
		19	9 500	5 433	6 908	9 120	9 500	3.23
		17	8 740	6 489	7 964	8 740	8 740	3.39
	45	22	9 500	2 821	4 296	6 508	7 983	3.56
		19	8 550	5 111	6 586	8 550	8 550	3.72
		17	7 790	6 545	7 790	7 790	7 790	3.88
<b>RTH-15 B/G</b>	25	22	16 920	4 991	7 562	11 417	13 991	3.99
		19	15 228	8 982	11 552	15 228	15 228	4.18
		17	14 100	11 613	14 100	14 100	14 100	4.37
	35	22	15 651	4 581	7 151	11 007	13 577	4.52
		19	14 100	8 573	11 143	14 100	14 100	4.75
		17	12 972	10 446	12 972	12 972	12 972	4.99
	45	22	14 100	4 122	6 692	10 548	13 119	5.23
		19	12 690	8 105	10 676	12 690	12 690	5.47
		17	11 562	10 628	11 562	11 562	11 562	5.70

## Sensible cooling capacities

Model	Dry temperature, outdoor air, °C (DB)	Humid temperature, air intake, °C (WB)	Total capacity	Sensible capacity (W)				Compressor absorbed power
				Dry intake air temperature to coil, °C (DB)				
				22	24	27	29	
			W	W	W	W	W	kW
<b>RTH-20 B/G</b>	25	22	21 480	6 463	9 189	13 279	16 009	4.39
		19	19 332	10 702	13 429	17 519	19 332	4.60
		17	17 900	13 490	16 216	17 900	17 900	4.81
	35	22	19 869	5 925	8 652	12 742	15 468	4.97
		19	17 900	10 169	12 895	16 985	17 900	5.23
		17	16 468	12 115	14 841	16 468	16 468	5.49
	45	22	17 900	5 326	8 053	12 143	14 869	5.75
		19	16 110	9 559	12 286	16 110	16 110	6.02
		17	14 678	12 209	14 678	14 678	14 678	6.28
<b>RTH-25 B/G</b>	25	22	26 040	7986	10 822	15 075	17 915	6.63
		19	23 436	12 398	15 223	19 487	22 327	6.95
		17	21 700	15 291	18 126	21 700	21 700	7.26
	35	22	24 087	7 314	10 149	14 403	17 238	7.50
		19	21 700	11 732	14 568	18 821	21 657	7.90
		17	19 964	13 049	15 884	19 964	19 964	8.29
	45	22	21 700	6 566	9 402	13 655	16 491	8.69
		19	19 530	10 974	13 810	18 064	19 530	9.08
		17	17 794	13 699	16 535	17 794	17 794	9.48
<b>RTH-30 B/G</b>	35	22	32 400	9 907	13 518	18 934	22 550	7.77
		19	29 160	15 524	19 135	24 551	28 169	8.14
		17	27 000	19 209	22 820	27 000	27 700	8.51
	25	22	29 970	9 074	12 685	18 101	21 712	8.79
		19	27 000	14 700	18 311	23 727	27 000	9.25
		17	24 840	17 274	20 884	24 840	24 840	9.72
	45	22	27 000	8 148	11 759	17 176	20 787	10.18
		19	24 300	13 761	17 372	22 788	24 300	10.64
		17	22 140	17 237	20 848	22 140	22 140	11.10

## Indoor fan services

Model	Available static pressure		Air flow		Absorbed power
	mm WG	Pa	m³/h	m³/s	W
<b>RTH-07 B/G</b>	8	78.4	1 615	0.45	395
	6	58.8	1 760	0.49	403
	4	39.2	1 865	0.52	410
	2	19.6	2 010	0.56	423
	0	0	2 120	0.59	433
	<b>RTH-10 B/G</b>	10	98	2 100	0.58
8		78.4	2 220	0.61	455
6		58.8	2 300	0.64	373
4		39.2	2 410	0.67	480
2		19.6	2 530	0.70	500
0		0	2 645	0.73	518
<b>RTH-15 B/G</b>	12	117.6	3 300	0.92	969
	10	98	3 600	1.00	990
	8	78.4	3 790	1.05	1018
	6	58.8	4 000	1.11	1055
	4	39.2	4 070	1.13	1078
	2	19.6	4 170	1.16	1087
	0	0	4 190	1.15	1 100
<b>RTH-20 B/G</b>	20	196	3 620	1	900
	16	156.8	4 015	1.12	980
	12	117.6	4 305	1.96	1 050
	10	98.0	4 360	1.21	1 080
	8	78.4	4 380	1.22	1 110
	6	58.8	4 455	1.24	1 140
	4	39.2	4 525	1.26	1 170
	2	19.6	4 610	1.28	1 205
	0	0	4 710	1.31	1 240
<b>RTH-25 B/G</b>	16	156.8	3 980	1.10	940
	12	117.6	4 400	1.22	1 050
	10	98	4 520	1.25	1 100
	8	78.4	4 750	1.31	1 160
	6.3	61.7	4 900	1.36	1 220
	4	39.2	5 180	1.43	1 290
	2	19.6	5 420	1.50	1 345
	0	0	5 500	1.52	1 390
<b>RTH-30 B/G</b>	16	156.8	4 700	1.30	1 220
	12	117.6	5 200	1.44	1 365
	10	98	5 350	1.48	1 430
	6.3	61.7	5 800	1.61	1 585
	4	39.2	6 050	1.68	1 680
	2	19.6	6 280	1.74	1 750
	0	0	6 400	1.77	1 810

## Outdoor fan services

Model	Available static pressure		Air flow		Absorbed power	
	mm WG	Pa	m³/h	m³/s	W	
<b>RTH-07 B/G</b>	10	98	2 020	0.56	445	
	8	78.4	2 190	0.61	460	
	6	58.8	2 315	0.64	470	
	4	39.2	2 430	0.68	486	
	2	19.6	2550	0.71	500	
	0	0	2665	0.74	514	
<b>RTH-10 B/G</b>	10	98	3 180	0.88	900	
	8	78.4	3 310	0.92	930	
	6	58.8	3 410	0.95	950	
	4	39.2	3 510	0.98	980	
	2	19.6	3 625	1.00	1 003	
	0	0	3 735	1.04	1 033	
<b>RTH-15 B/G</b>	10	98.0	3 970	1.10	1000	
	8	78.4	4 170	1.16	1070	
	6	58.8	4 320	1.20	1142	
	4	39.2	4 425	1.23	1180	
	2	19.6	4 520	1.26	1205	
	0	0.0	4 635	1.29	1235	
	<b>RTH-20 B/G</b>	16	156.8	4 410	1.23	990
10		98.0	4 970	1.38	1 130	
8		78.2	5 100	1.42	1 170	
6		58.7	5 210	1.45	1 205	
4		39.1	5 317	1.48	1 235	
2		19.6	5 428	1.51	1 275	
0		0.0	5 525	1.54	1 305	
<b>RTH-25 B/G</b>		14	137.2	4 500	1.25	1 130
		10	98	4 800	1.33	1 200
	8	78.4	4 910	1.36	1 250	
	6	58.8	5 050	1.40	1 275	
	5.1	50	5 250	1.44	1 295	
	4	39.2	5 270	1.45	1 320	
	2	19.6	5 350	1.48	1 335	
	0	0	5 450	1.51	1 388	
<b>RTH-30 B/G</b>	14	137.2	5 490	1.52	1 355	
	10	98	5 980	1.66	1 440	
	8	78.4	6 200	1.72	1 500	
	5.1	50	6 400	1.77	1 555	
	4	39.2	6 480	1.8	1 585	
	2	19.6	6 600	1.83	1 600	
	0	0	6 700	1.86	1 665	

## Electrical characteristics

Model	Power supply V.ph.Hz.		Consumption A				Minimum power supply cable section (2) mm <sup>2</sup>	Automatic switch (K curve) (1) A
	Compressor	Fan	Compressor		Outdoor fan	Indoor fan		
		Outdoor - Indoor	Start	Nominal	Run	Run		
<b>RTH-07 B/G</b>	230.1.50		72	13	2	1.9	4	25
<b>RTH-10 B/G</b>	230.3.50		90	9.6	4.5	2	4	25
	400.3.50	230.1.50	45	5.5	4.5	2	2.5	20
<b>RTH-15 B/G</b>	230.3.50		124	13.1	5.4	5.1	6	32
	400.3.50		62	7.5	5.4	5.1	4	25
<b>RTH-20 B/G</b>	230.3.50	230.3.50	165	16.7	4.9	5.1	10	40
	400.3.50	400.3.50	79	9.6	2.8	2.9	4	25
<b>RTH-25 B/G</b>	230.3.50	230.3.50	170	22.5	5.1	4.9	10	40
	400.3.50	400.3.50	77	12.9	2.9	2.8	4	25
<b>RTH-30 B/G</b>	230.3.50	230.3.50	215	26.1	7.2	4.6	10	50
	400.3.50	400.3.50	80	15	4.1	2.6	6	32

**Important:** Automatic switch dimensioning and power supply and operating line sections are orientative and should be corrected in accordance with conditions at job site, length between units and legislation in force.  
**Notes:** 1.- K curve (DIN, VDE 0660-104). 2.- Based on copper conductors.

## Operation

The control board of these units is common to both the cool only as well as the heat pump units. By connecting an additional module, two-compressor equipment can be controlled. Equipment control is carried out by means of software that is resident in the board. The System operates in accordance with the position of the microswitches in the main board. There are also variations in the control algorithm, depending upon the accessories the board detects installed in the equipment.

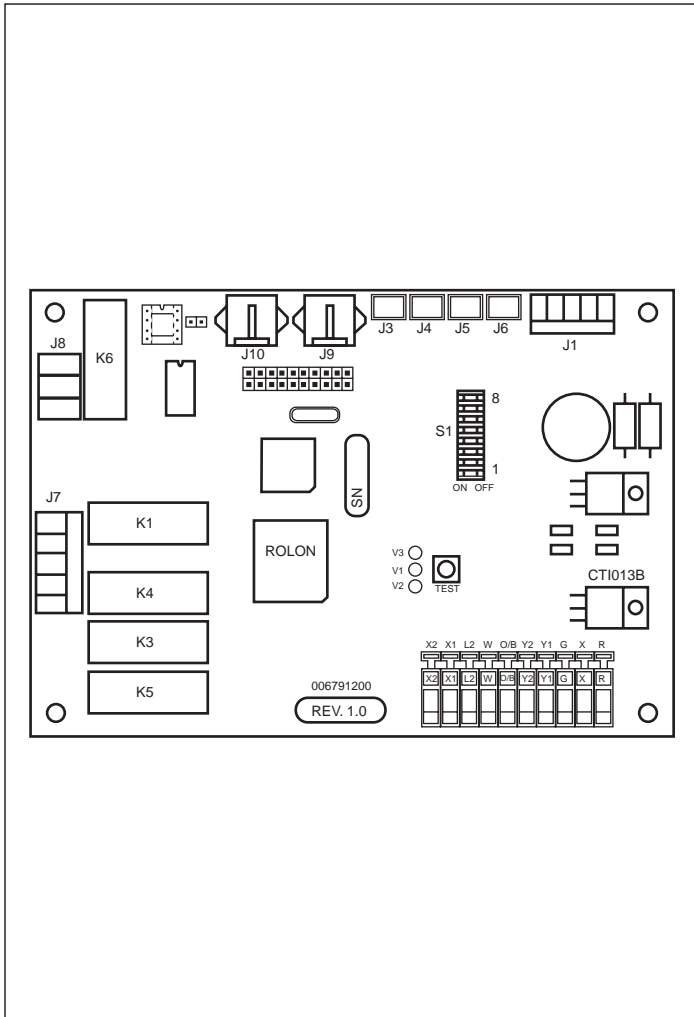

### Indoor fan

Operation can be continuous or automatic. For continuous operation, select said operation on the thermostat. If the internal probe (optional accessory) is installed, and the operating mode is heat, the fan will not start until the indoor coil has reached 35°C, and will stop when this temperature drops to below 30°C. Whenever the electric heating starts, the indoor fan will also start.

### Outdoor fan

The outdoor fan starts 5 seconds before the compressor. And stops after the compressor stops.

### Four-way valve

When SW6 of the control board is set to ON, the four-way valve activates when the thermostat requests heat. When a defrost cycle is carried out, this valve operates inversely; that is to say, in cool.

### Compressor

When signal Y1 is present, the board commands the outdoor

fan to become operative, and then the compressor. The compressor, along with the outdoor fan, does not start until after a minimum off time, so as to avoid consecutive start-ups. This period of time can be set by means of microswitches SW4; ON = 2' and OFF = 5'.

In two-stage equipment, the first compressor to start up will be the one that has been less hours in operation.

The second compressor will start if a Y2 signal is received from the thermostat.

Whenever one of the compressors is to turn off, it will be the one that has been most hours in operation.

### Defrost

The defrost cycle is possible only in heat pump operation. In two-stage units, simultaneous defrost of both stages is not allowed, one remaining in standby until the other one has finished.

### Start-up

The following conditions should apply:

- 1) The compressor is on.
- 2) The liquid probe temperature is below -3°C for 3'.
- 3) If outdoor temperature is below 0°C, after compressor start-up 5' are timed before activating the defrost cycle.

When the defrost cycle is started, the board carries out the following operations:

- 1) Sets the 4-way valve to cool mode.
- 2) Turns the outdoor fan off.
- 3) Activates the following heat-generating phase, if the thermostat requires heat.
- 4) Turns the indoor fan off if there is no next heat stage.
- 5) Does not turn off the compressor that is defrosting, even if indicated by the thermostat.

### End

This operation will last until one of the following conditions is completed:

- a) Liquid temperature above 13°C during 2".
- b) Liquid temperature above 5°C during 30".
- c) Timing period after defrost start-up over 10'.
- d) Failure signal from high pressure switch.

Once defrost is over:

- 1) Sets four-way valve to heat.
- 2) Turns outdoor fan on.
- 3) Starts indoor fan if no next heat stage exists.
- 4) Turns off heat generating phase that started due to the defrost cycle.

### Test button and LEDs

The Test button shortens certain timings, resets any failure detected and also acts as a LonWorks service pin.

There are three signalling led diodes:

- a) The green led indicates correct operation of the equipment and incidents. If the equipment is operating correctly, this led flashes at a frequency of 1.6 Hz.
- b) The red led indicates failures. If no failure is present, this led remains off.
- c) The yellow led is the LonWorks service led, and also indicates, by flashing, that the operating compressor is timed.

### Configuration

Each time the electronic board is powered, system configuration will be checked, with the exception of the accessories. Below we can see how the different options are configured.

## Microswitches

They are read after power supply connection, and the board will act in accordance with their position. SW1 and SW2 set to OFF indicates that the configuration is carried out by remote control, and the parameters stored in the EEPROM memory are use.

## Configuration of switches

The microswitches establish the following configurations:

Number	State	Meaning
1 / 2	OFF/OFF	Ignore SW, programs communication routes
	ON/OFF	Defrost period 30'
	OFF/ON	Defrost period 60'
	ON/ON	Defrost period 90'
3	ON	Indoor fan ON during defrost
	OFF	Indoor fan OFF during defrost
4	ON	Compressor delay 2'
	OFF	Compressor delay 5'
5	ON	Cool mode
	OFF	Heat pump mode
6	ON	4-way valve active in heat
	OFF	4-way valve active in cool
7	ON	Receives signal B from thermostat (active in heat)
	OFF	Receives signal O from thermostat (active in cool)
8	ON	NA
	OFF	NA

## Configuration of accessories

To carry out an accessory search and configuration, the test button should be pressed for over two seconds, until the red led goes on. Once the search and configuration process begins, the red led on the board goes on, and stays on until the operation is concluded. Once off, the board uses the accessories found.

In said search the board will also detect which optional probes are connected to the board. A incident will be give if one of the optional probes detected in the configuration process does not give valid values.

The following table shows the configuration of the probes.

Probe	Pump	
	Obligatory	Optional
Discharge	X	
Liquid	X	
Outdoor	X	
Suction	X	
Indoor coil		X

## Installation of accessories

The accessories are used to support extended functions of the unit.

Said accessories can be either factory mounted or installed at the client's facilities. Power supply to the unit should always be disconnected. The accessory, along with the necessary elements, will then be assembled, and the power supply connected once again.

Once the search and configuration sequence is carried out, the new elements will be recognised and they will begin to operate.

The function of the different accessories is defined below.

### Tray heater

A cable heater is used, mounted between the lower area of the outdoor coil and the tray, where the defrost water is collected. Its function is to avoid freezing of the water in the tray and ice in the lower area of the coil.

This heater should be activated in the winter cycle, while the compressor is operative, and when the liquid temperature is below -2°C; and deactivated when the temperature is above 2°C.

### Electric heating

In the case of the heaters, the relay is used to switch the power contactor on and off, as well as the thermal switch with safety automatic reset.

In one-stage equipment, the response to a demand for first stage from the thermostat starts the compressor stage, and the second starts the electric heating.

In the case of a failure in the compressor stage, the electric heating would be activated as the first stage.

Whenever the electric heating is on, the indoor fan will also be operative.

### Indoor coil probe

The probe in the indoor coil, depending upon the temperature, carries out the following operations:

- 1) If in heat operating mode, and the electric heater is not activated, the fan will not start until the indoor coil reaches 35°C. If the electric heating is not activated, the indoor fan will turn off if the temperature drops below 30°C. If once the compressor is operating in heat mode for 2' the indoor temperature does not reach over 35°C, an unrecoverable heat temperature incidence is indicated.
- 2) If in cool operating mode, and the probe temperature is below -25°C, or the compressor is in operation for over 5' and the temperature is below -4°C, the compressor and outdoor fan go off. After the timed period, the compressor starts again. If this is repeated 3 times in 35 minutes, a failure of repeated start-up in cool is indicated, and the compressor will not restart.

## Malfunctions

There are two different types of malfunctions: incidents that do not turn the unit off, and failures or lockouts, that inactivate the unit.

### Indoor fan thermal switch

Its activation turns the entire unit off, and an indoor fan thermal switch failure is indicated.

### High and low pressure switch

Its activation turns the compressor and outdoor fan off. A high or low pressure failure of the switch is indicated.

## Electric heating thermal switch (accessory)

Activation turns the electric heating off and indicates an incident. If this error occurs more than 3 times in an hour, an electric heater thermal switch incident is indicated, it is inhibited, and the electric heater is turned off.

## Thermostat errors

If signal Y is given without signal G, it acts as if signal G were active. An incident of signal Y1 without signal G is indicated. If signal W is given without signal G, it acts as if signal G were active. An incident of signal W without signal G is given. If signal W is given without signal B/O, it acts as if signal B/O were indicating heat mode. An incident of signal W without signal B/O is given.

## Protection for defrost cycles

If 3 consecutive defrost cycles are carried out and ended in compliance with the 10' timer, an incident of repeated defrosts is indicated. This incident is deleted when a defrost cycle is ended in compliance with another condition that is not the maximum timer period.

## Protection for temperature

- If the outdoor temperature is below  $-20^{\circ}\text{C}$ , the compressor turns off. An incident of low outdoor temperature (only in heat mode) is indicated.
- If the discharge temperature is above  $130^{\circ}\text{C}$ , the compressor and outdoor fan turn off. An excessive discharge temperature failure is indicated.
- If while the compressor is on for 5', the discharge temperature does not rise above  $50^{\circ}\text{C}$ , in cool mode, or  $35^{\circ}\text{C}$  in heat mode, a low discharge temperature incident is indicated.
- If the suction temperature is very low, the compressor and outdoor fan turn off. If this is repeated 3 times in 35 minutes, a failure is indicated.
- If, in heat mode, the liquid temperature is below  $-30^{\circ}\text{C}$ , the compressor and outdoor fan turn off, and a failure is indicated.

## Open or short circuit of the outdoor or indoor liquid probe

An incident of the corresponding probe is indicated if the value read is below  $-40^{\circ}\text{C}$ , or above  $100^{\circ}\text{C}$ . If this incident takes place in heat mode in the liquid probe, repeated defrost cycles are carried out with a maximum duration of 30".

## Open or short circuit of discharge probe

An incident of the discharge probe is indicated if its value is below  $-20^{\circ}\text{C}$ , or above  $150^{\circ}\text{C}$ . If the probe is short circuited, a failure is indicated.

## Signalling

Malfunction signalling is carried out at two levels. One for incidents and another for failures.

## Incidents

Incidents do not turn the unit off, and are indicated by the green led on the electronic board. If there is no failure present, this led flashes at a frequency of 1 Hz.

When an incident occurs, the led flashes in three sequences. The first indicates the compressor involved: one flash for stage 1, and two for stage 2, followed by a short pause. The second indicates the type of incident. Another short pause. The third

indicates the incident detected, followed by a long pause, and the sequence is repeated again as long as the incident lasts.

The incidents reset when the cause disappears. In the case of more than once incident at the same time, only the first one detected and not reset is indicated. As they reset, the other existing incidents not reset will be indicated.

In the following table shows the possible incidents:

Type	Flashes 2 <sup>a</sup>	3 <sup>a</sup>	Incident
Probes	1	1	Discharge probe open or $>150^{\circ}\text{C}$
	1	2	Liquid probe open or short circuited
	1	3	Outdoor probe open or short circuited
	1	4	Indoor probe open or short circuited
	1	5	Outdoor temperature too low
Thermostat	2	1	Signal Y1 or Y2 without signal G
	2	2	Signal W without signal B
	2	3	Signal W without signal G
	2	4	Signal Y2 without signal Y1
Electric heater	3	1	Electric heater thermal switch AUX1
	3	2	Electric heater thermal switch AUX2
	3	3	Electric heater thermal switch EM1
	3	4	Electric heater thermal switch EM2
Temperature	4	1	Repeated defrost cycles
	4	2	Discharge temperature does not recover
	4	4	Temperature in heat does not recover
Others	5	1	ID of transceiver unknown
	5	2	Accessory disappeared

## Failures (lockouts)

Failures or lockouts turn the unit off.

They are indicated by the red led on the board, and by means of the thermostat (depending upon the model). Relay K6 of the board is also activated with a 24 VAC signal between terminals LED2 and B of J2. If no failure is present, this led remains off. When a failure takes place, this led flashes in two sequences. The first indicates the compressor involved: one flash for stage 1 and two for stage 2, followed by a short pause. Then the detected failure is indicated, followed by a long pause and the sequence is repeated.

Should more than one alarm take place, only the first one

detected and not reset is indicated.

The following table shows the possible failures:

Flashes	Meaning
1	Discharge temperature exceeded, or probe short circuited
2	High pressure switch, outdoor fan thermal switch or compressor module thermal switch
3	Low pressure switch
4	Indoor fan thermal switch
5	Repeated start ups in cool, or suction temperature <-25°C
6	Low liquid temperature <-30°C

## Reset

The incidents, with a few exceptions, do not need to be reset. They reset automatically once the cause has disappeared. The following incidents require resetting, and are reset in the same way as the alarms:

- a) Accessory disappeared.
- b) Repeated defrost cycles (also reset if a defrost cycle ends under normal conditions).
- c) Electric heating thermal switch.

These alarms can be reset as follows:

- 1) Setting the thermostat to OFF, if communication with the thermostat has been implemented.
- 2) Pressing the reset button on the electronic board.
- 3) Disconnecting and reconnecting power supply to the electronic board.
- 4) By means of the communications trunk.

It is worth pointing out that, with a reset by means of setting the thermostat to OFF, the board cannot be reset more than 3 times a day.



# Wiring diagram

RTH-07 B/G, 230.1.50

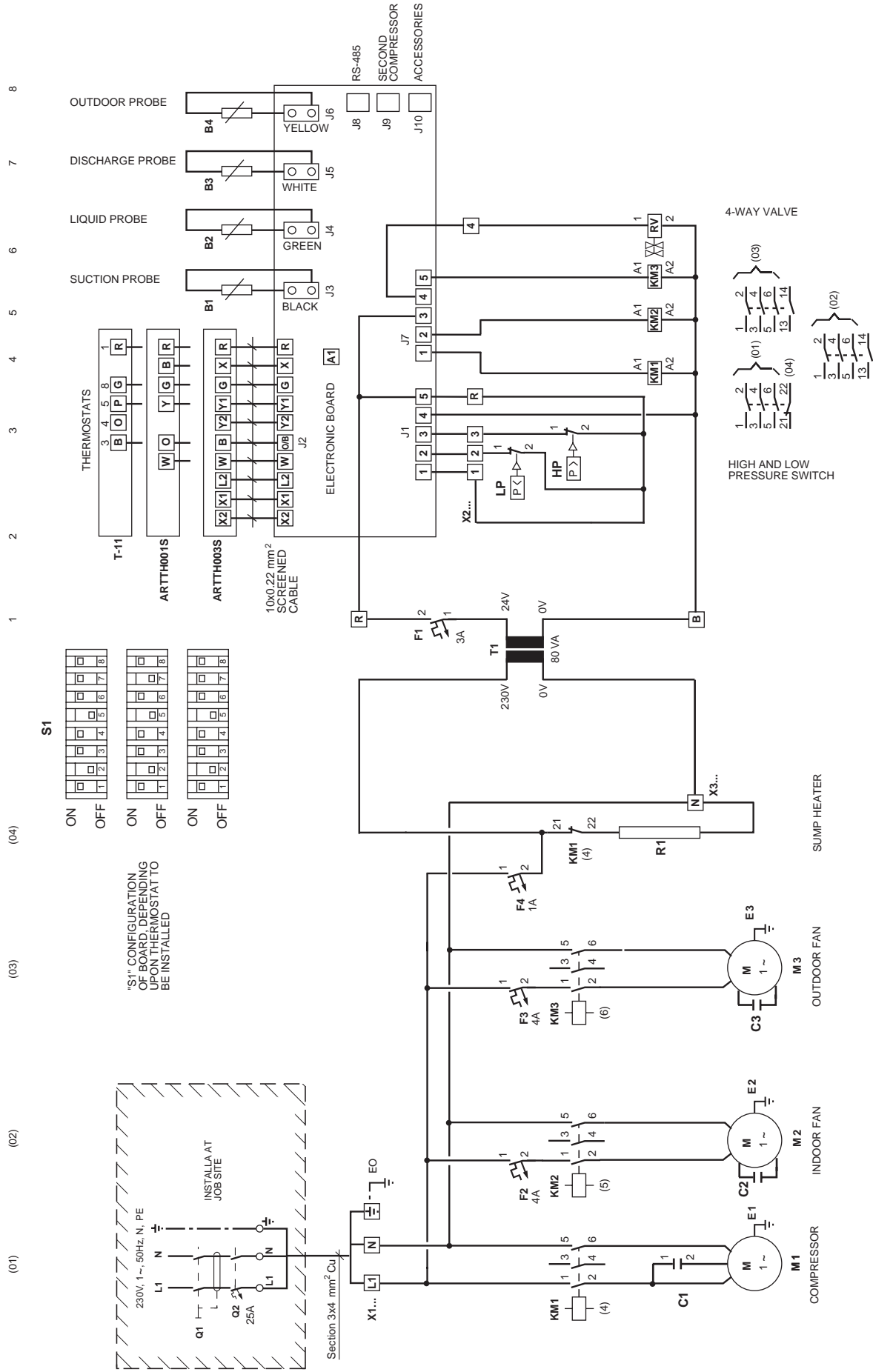

THE COMPONENTS INCLUDED IN THESE BOXES ARE NOT SUPPLIED BY THE MANUFACTURER.

# Wiring diagram

RTH-10-15 B/G, 400.3.50

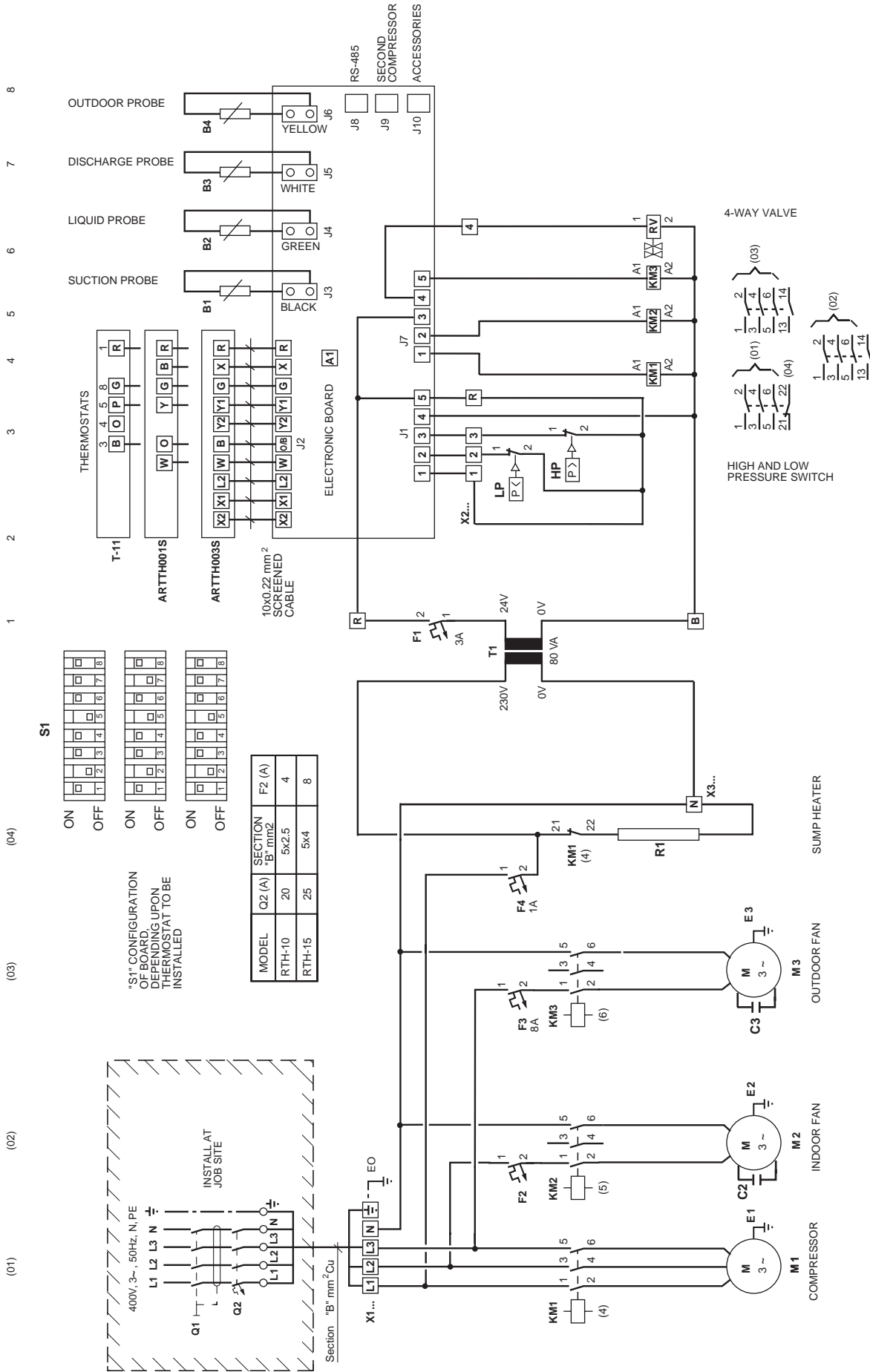

S1

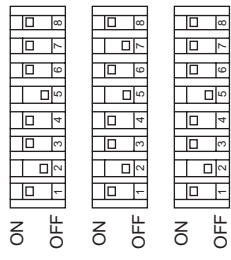

"S1" CONFIGURATION OF BOARD, DEPENDING UPON THERMOSTAT TO BE INSTALLED

MODEL	Q2 (A)	SECTION "B" mm <sup>2</sup>	F2 (A)
RTH-10	20	5x2.5	4
RTH-15	25	5x4	8

THE COMPONENTS INCLUDED IN THESE BOXES ARE NOT SUPPLIED BY THE MANUFACTURER.

I-19729  
RTH-10-15 B/G  
400.3.50

# Wiring diagram

RTH-20-25-30 B/G, 400.3.50

(01) (02) (03) (04) (05) 1 2 3 4 5 6 7 8

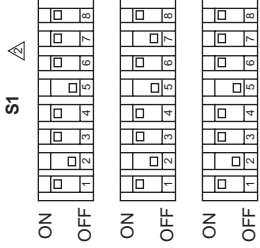
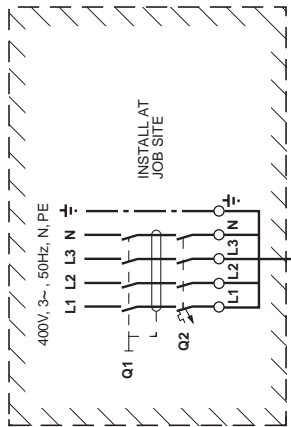

'S1' CONFIGURATION OF BOARD, DEPENDING UPON THERMOSTAT TO BE INSTALLED

MODEL	Q2 (A)	SECTION "B" mm <sup>2</sup>	REG. F3
RTH-20	25	5x4	4
RTH-25	25	5x4	4
RTH-30	32	5x6	5

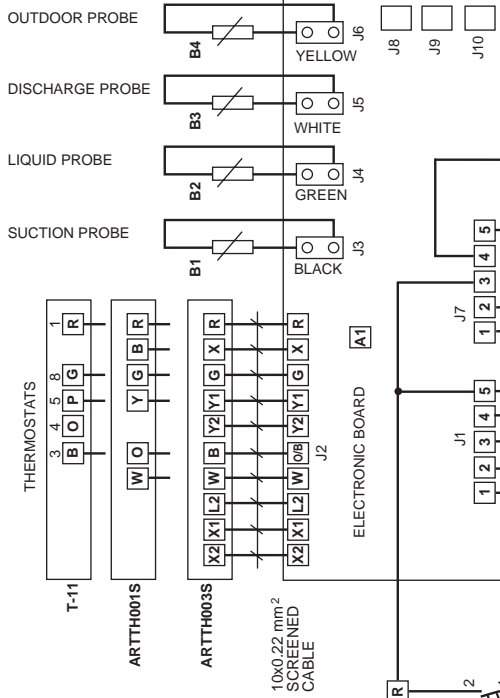

RS-485 SECOND COMPRESSOR ACCESSORIES

10x0.22 mm<sup>2</sup> SCREENED CABLE

ELECTRONIC BOARD A1

230V 0V 80 VA

24V 0V

COMPRESSION MODULE

SUMP HEATER

INDOOR FAN

OUTDOOR FAN

AUX. CONTACT MOTOR GUARD

HIGH AND LOW PRESSURE SWITCH

4-WAY VALVE

COMPRESSOR

INDOOR FAN

OUTDOOR FAN

COMPRESSION MODULE

SUMP HEATER

COMPRESSOR

I-1953g  
RTH-20-25-30 B/G  
400.3.50

THE COMPONENTS INCLUDED IN THESE BOXES ARE NOT SUPPLIED BY THE MANUFACTURER.

- △ - PROTECTION MODULE A2 IS MOUNTED ON SCROLL COMPRESSORS ONLY
- △ --MICROSWITCH NO. 6 (S1) MUST BE SET TO OFF ON MODELS BCH-252 AND 302 WITH R22 REFRIGERANT AND VALVE INSTALLED SO AS TO ACTIVATE IN SUMMER CYCLE

# Wiring diagram

RTH-10-15 B/G, 230.3.50

(01) (02) (03) (04)

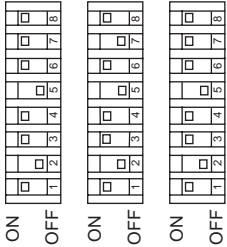
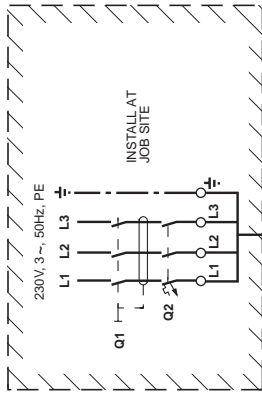

"S1" CONFIGURATION OF BOARD DEPENDING UPON THERMOSTAT TO BE INSTALLED

MODEL	Q2 (A)	SECTION "B" mm <sup>2</sup>	F2 (A)
RTH-10	25	4x4	4
RTH-15	32	4x6	8

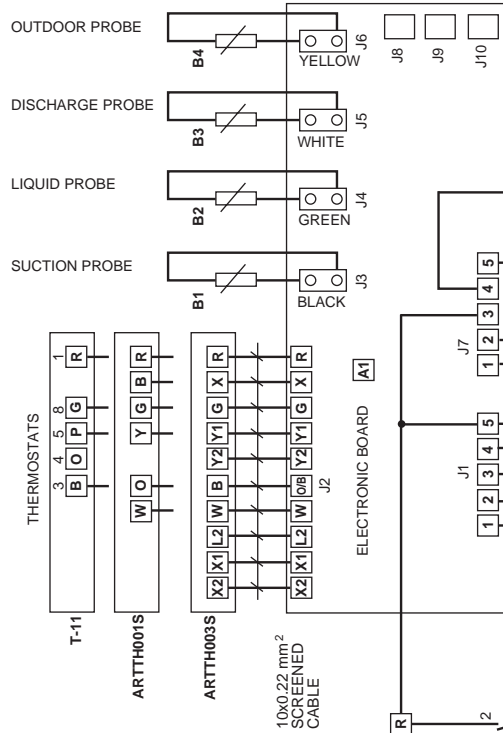

RS-485  
SECOND COMPRESSOR  
ACCESSORIES

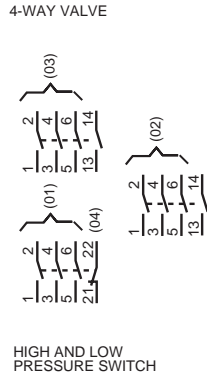
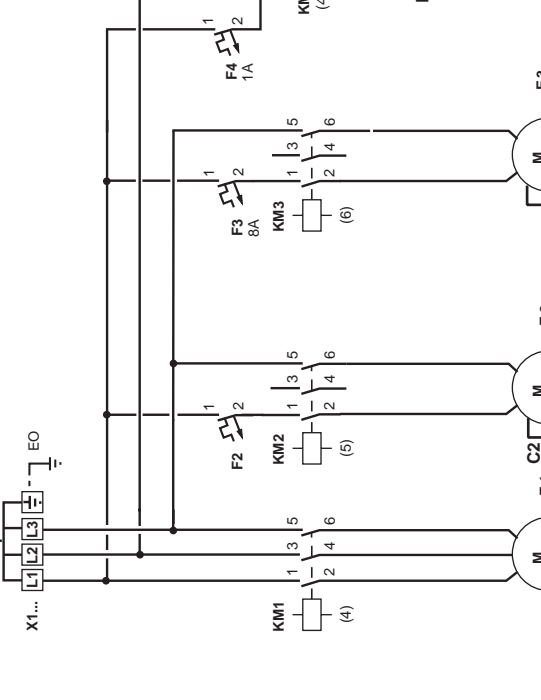
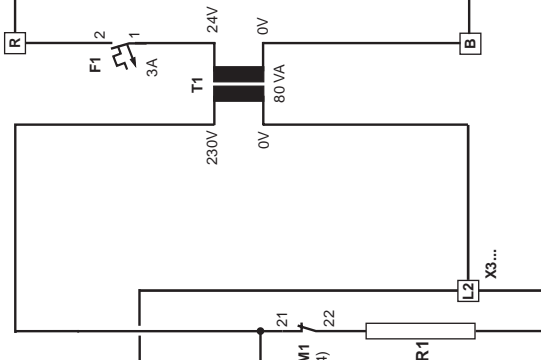
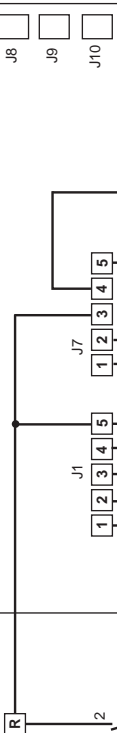

THE COMPONENTS INCLUDED IN THESE BOXES ARE NOT SUPPLIED BY THE MANUFACTURER.

I-1973g  
RTH-10-15/B/G  
230.3.50

# Wiring diagram

RTH-20-25-30 B/G, 230.3.50

(01) (02) (03) (04) (05) 1 2 3 4 5 6 7 8

S1

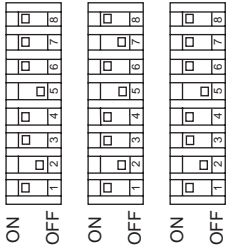

"S1" CONFIGURATION OF BOARD, DEPENDING UPON THERMOSTAT TO BE INSTALLED

MODEL	Q2 (A)	SECTION "B" mm <sup>2</sup>	REG. F3
RTH-20	40	4x10	6
RTH-25	40	4x10	6
RTH-30	50	4x10	8

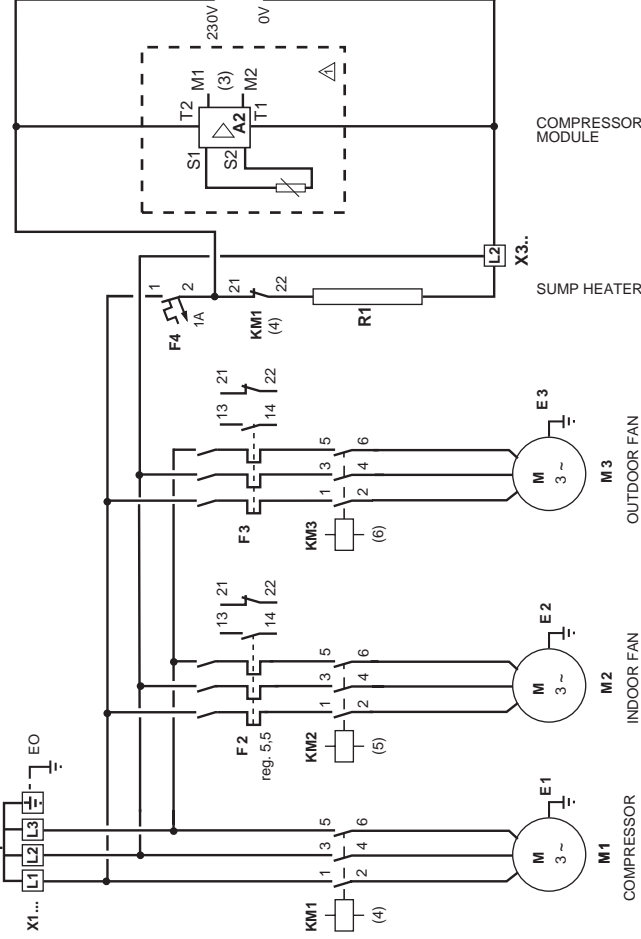
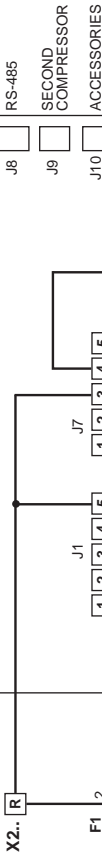
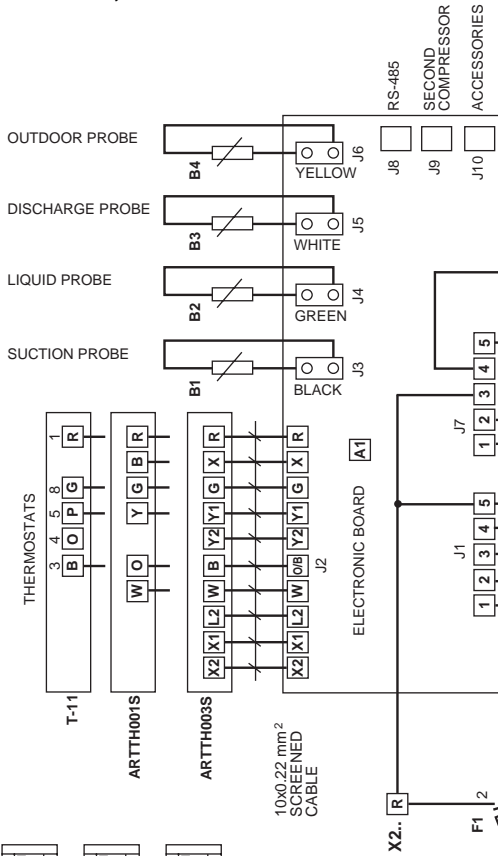
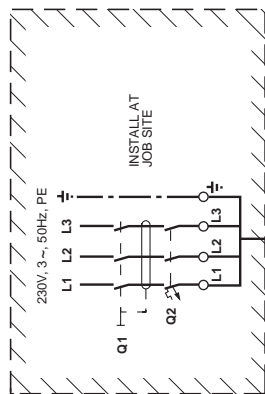

- △ - PROTECTION MODULE A2 IS MOUNTED ON SCROLL COMPRESSORS ONLY
- △ - MICROSCHWITCH NO. 6 (S1) MUST BE SET TO OFF ON MODELS BCH-252 AND 302 WITH R22 REFRIGERANT AND VALVE INSTALLED SO AS TO ACTIVATE IN SUMMER CYCLE

I-1970g  
RTH-20-25-30 B/G  
230.3.50

THE COMPONENTS INCLUDED IN THESE BOXES ARE NOT SUPPLIED BY THE MANUFACTURER.

## Accessories

### Duct electric heaters for RTC/RTH-07 to 30 B/G

These duct electric heaters are designed to provide backup heat in the RTH units, and complementary heat in the RTC units. On and off cycles are governed by the air conditioning equipment control system. These should be fitted directly to the impulse outlet of the indoor section of the unit.

#### Technical specifications

These duct electric heaters include the following components:

- Galvanised sheet casing, covers and supports.
- Exposed nickel-chrome wire electric resistance mounted on steatite supports.

- Power supply contactor with a 230 V coil on one-phase heaters, and a 400 V coil on three-phase heaters.
- Two thermal switches located at the top of the heater. The first, with automatic reset, disconnects the heater when a temperature of 77°C is reached. The second, accessible externally and with manual reset, disconnects the heater when a temperature of 138°C is reached.
- Interlock with the indoor fan thermal relay on models RTC/RTH-20, 25 and 30 B/G. The control system of the unit does not allow operation of the heater when the indoor fan thermal relay fails.
- Plug-in connector for interconnection between the control panel of the air conditioning unit and the heater.
- PVC gasket for heater-air conditioner joint and self-threading screws for fastening the accessory.

#### General dimensions mm

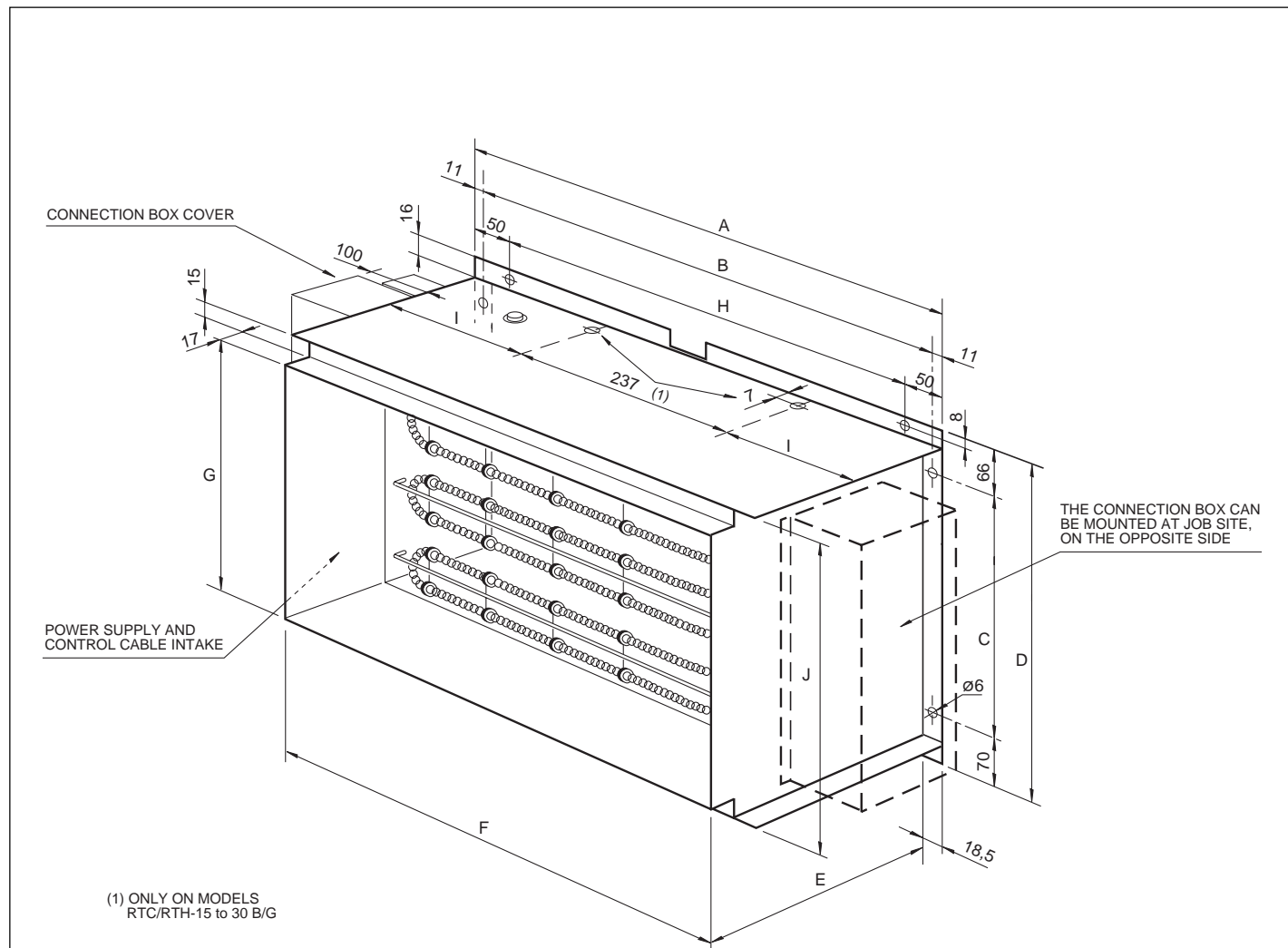

Model	A	B	C	D	E	F	G	H	I	J
RTC/RTH-72 & 102	400	378	285	385	275	362	320	300	-	353
RTC/RTH-152 & 302	527	505	310	447	350	490	380	427	145	412

## General characteristics

Heater model	Power supply	Power	Consumption	Stages	Automatic switch (1) Q1	Power supply cable section (2)	Front surface	Pressure drop (3)
	V.ph.Hz	kW	A		A	mm <sup>2</sup>	m <sup>2</sup>	Pa
<b>RTC/RTH-07</b>	230.1.50	5	22	1	25	4	0.12	6
<b>RTC/RTH-07 &amp; 10</b>	400.3.50	5	8	1	10	1,5	0.12	6
<b>RTC/RTH-07 &amp; 10</b>	400.3.50	10	15	1	20	2,5	0.12	6
<b>RTC/RTH-15 to 30</b>	400.3.50	10	15	1	20	2,5	0.19	15
<b>RTC/RTH-15 to 30</b>	400.3.50	15	22	1	25	4	0.19	15

**Notes:** 1.- K curve (DIN, VDE 0660-104). 2.- Based on copper conductors. 3.- Considered the nominal air flow of the indoor section.

## Dimensions with packing and weights

Heater model	Dimensions with packing mm			Weight kg
	Height	Width	Depth	
<b>RTC/RTH-07 &amp; 10</b>	360	513	293	15
<b>RTC/RTH-15 &amp; 30</b>	440	640	370	20

## Installation

Install the electric heater in the RTC/RTH unit as follows:

- 1) In all cases, the **established national regulations** should be followed.
- 2) Disconnect the power supply to the air conditioning unit.
- 3) Install the magnetothermal and differential switches for the heater in accordance with the table of General Characteristics and the Wiring Diagrams.
- 4) Remove the access panels of the RTC/RTH unit control box.
- 5) Unpack the accessory, opening the top of the box. Make sure the heater assembly has not been damaged during transportation. Check the ceramic insulation and that the heater wires are not in contact with any metal parts.
- 6) Fit the electric heater in the mouth of the indoor fan panel housing and drill eight 3 diameter holes for fastening. Check to make sure that the reset push button of the F9 thermal switch is accessible and at the top. See Heater Location diagram.
- 7) Fasten the PVC gasket, supplied with the accessory, to the frame surface of the heater adjacent to the indoor fan panel.
- 8) Fasten the heater to the panel with the screws supplied.
- 9) Remove the electrical connections cover of the heater and connect the power supply cables to connecting strip X1. Connect the control cable supplied, between connector J1 of the A3 Auxiliary Resistance board, and connector J10 of the A1 control board of the air conditioning unit.
- 10) The installer should complete the electric circuit of the heater by fitting an air flow control F14 at the most convenient point of the ducts so as to make sure the heater operates only when there is sufficient air flow.
- 11) Connect power supply to the RTC/RTH unit and the heater.

- 12) To configure the accessory, press the test button of control board A1 for over 2 seconds, until the red led on the board goes on. Configuration will be complete when said led goes off.
- 13) Check operation of the heater by selecting the Emergency Heat mode at the ambient thermostat of the air conditioning unit.
- 14) Assemble the electrical box covers of the heater and the RTC/RTH unit.

**Note:** Should an incorrect response of the system take place, see the Operation section of the RTC/RTH Installation Instructions. There you will find the control functions of the A1 electronic board on the heater, as well as its configuration, incidents identification, etc.



Loose cables can cause overheating of the terminals or incorrect operation of the unit. Fire hazards may also arise. Therefore, make sure all cables are connected tightly.

# Heater location

RTC/RTH-07 to 30 B/G

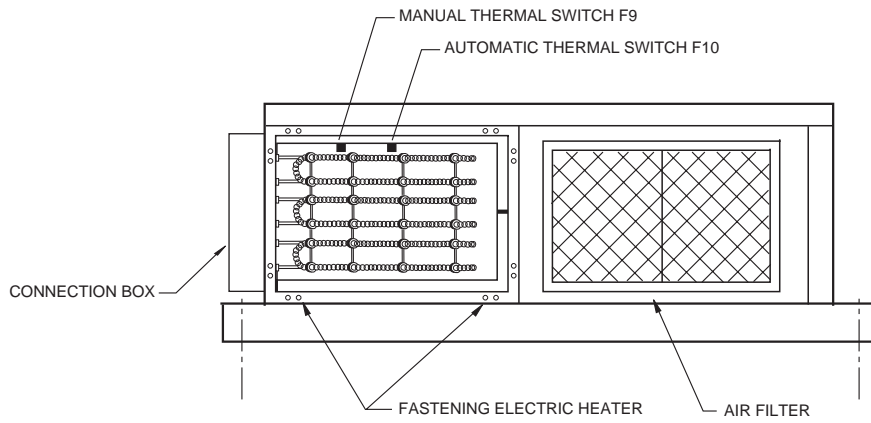
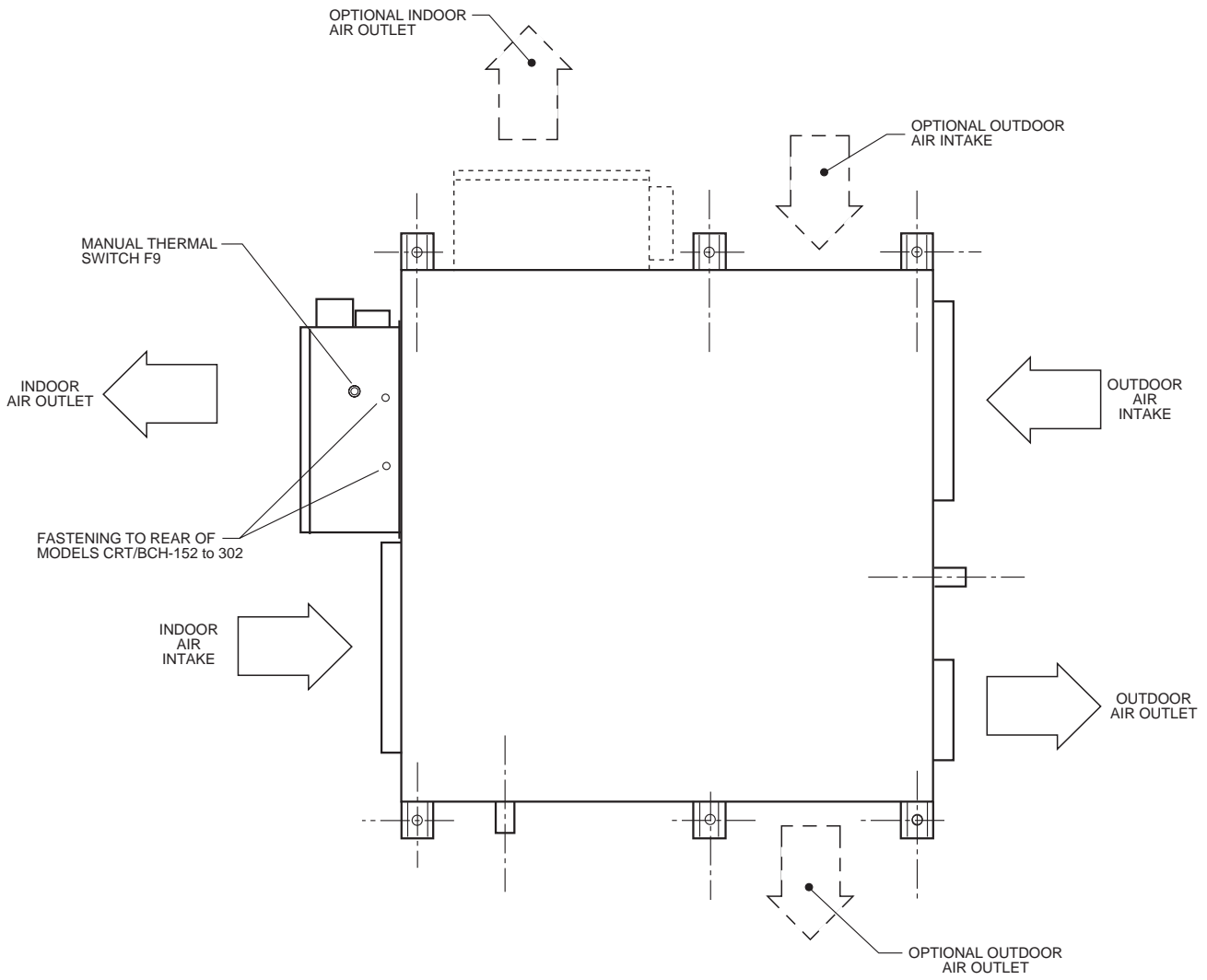



# Wiring diagram

**Heater 5kW, 230.1.50**  
**RTC/RTH-07 to 30 B/G**

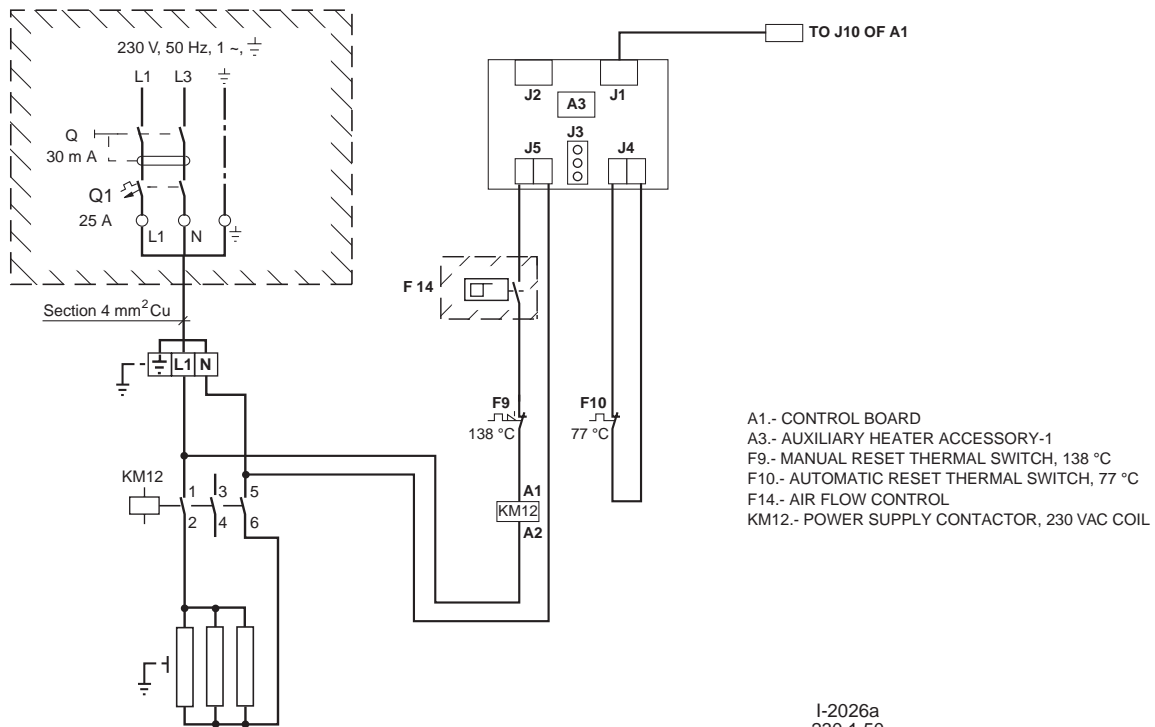

$\square \diagup \diagdown \square$  THE COMPONENTS INCLUDED IN THESE BOXES  
 $\square \diagdown \diagup \square$  ARE NOT SUPPLIED BY THE MANUFACTURER.

IMPORTANT: THE SIZE OF THE CIRCUIT BREAKER AND THE CROSS-SECTION OF THE SUPPLY AND CONTROL LINES ARE ONLY AS A GUIDE AND SHOULD BE CORRECTED IN ACCORDANCE WITH THE CONDITIONS AT THE JOBSITE, DISTANCE BETWEEN UNITS, AND CURRENT LEGISLATION.

# Wiring diagram

**Heater 5, 10, 15kW, 400.3.50**  
**RTC/RTH-07 to 30 B/G**

POWER kW	AUTOMATIC SWITCH Q1	MINIMUM CABLE SECTION mm <sup>2</sup>
5	10	1,5
10	20	2,5
15	25	4

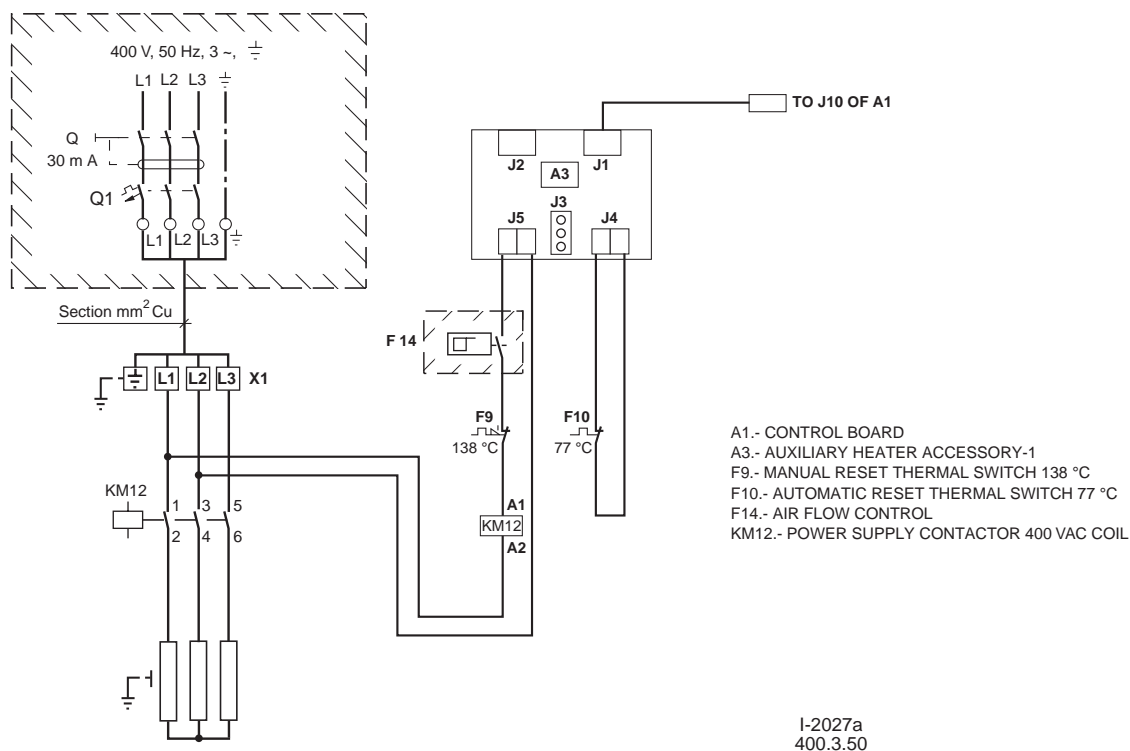

$\square$   $\diagup$   $\diagdown$   $\diagup$   $\diagdown$  THE COMPONENTS INCLUDED IN THESE BOXES  
 $\diagdown$   $\diagup$   $\diagdown$   $\diagup$  ARE NOT SUPPLIED BY THE MANUFACTURER.

IMPORTANT: THE SIZE OF THE CIRCUIT BREAKER AND THE CROSS-SECTION OF THE SUPPLY AND CONTROL LINES ARE ONLY AS A GUIDE AND SHOULD BE CORRECTED IN ACCORDANCE WITH THE CONDITIONS AT THE JOBSITE, DISTANCE BETWEEN UNITS, AND CURRENT LEGISLATION.





Ref.: Y-R70024 0203